

Thermal Wave® II HP

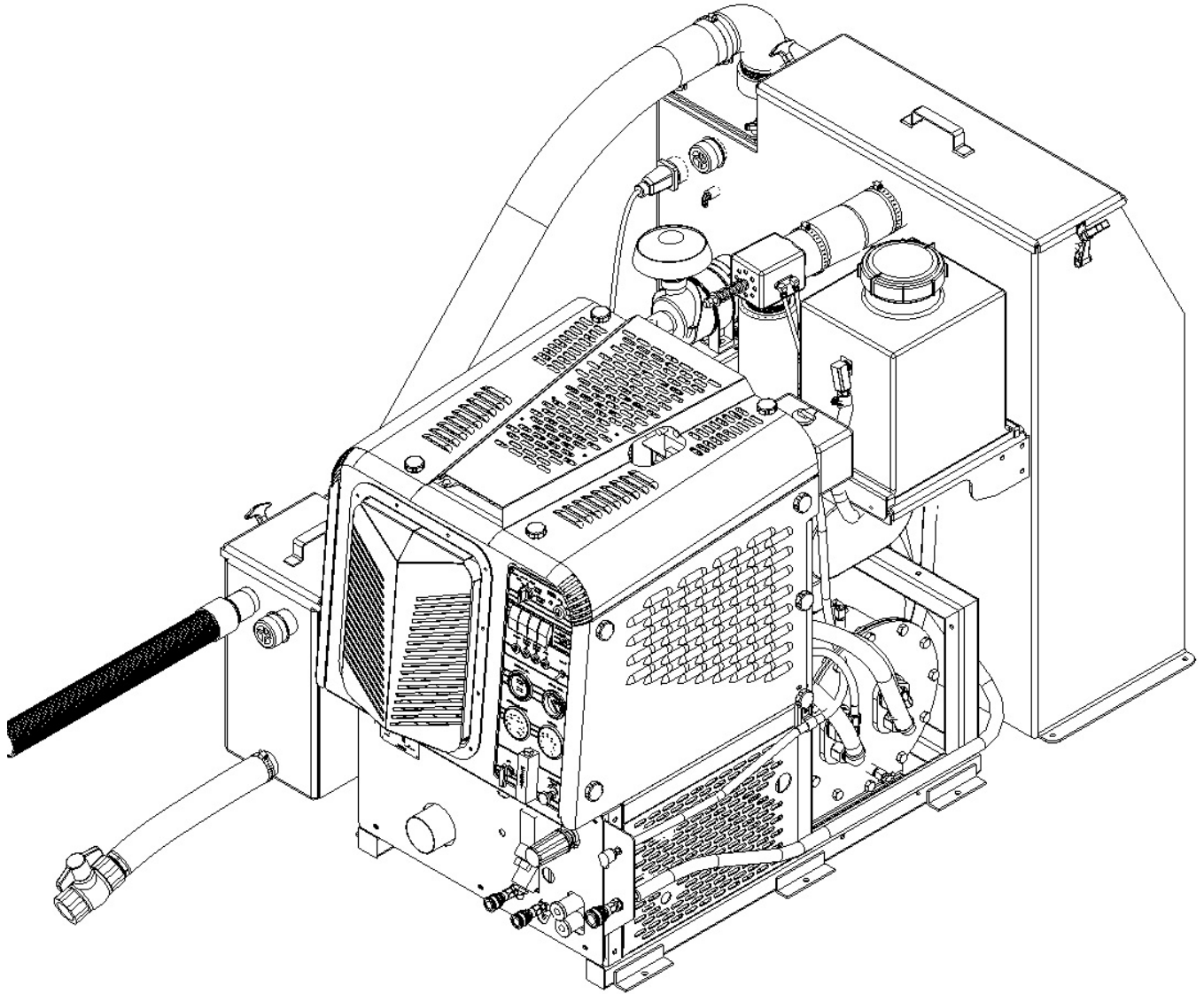

Service and Operation Manual

BLUELINE Equipment Co. LLC

2604 Liberator Dr., Prescott, AZ 86301 1-928-445-3030

Congratulations on your purchase of the **THERMALWAVE II HP®** truck mount cleaning unit. This instruction/parts manual is a guide for operating and servicing your **BLUELINE** truck mount unit.

Proper operation and service are necessary to ensure the outstanding performance of this unit. When properly maintained, your truck mount will have a long and trouble-free life.

The following service methods outlined in this manual are detailed in a manner that operation and servicing may be performed properly and safely. Because service levels vary due to the skill of the mechanic, tools and parts availability, ensure that prior to attempting any repair, you are familiar with this equipment and have the proper tools. Any questions regarding the operation, service, or repair of this unit should be directed to your nearest **BLUELINE** dealer.

The headings **WARNING** and **CAUTION** are utilized to warn you that steps must be taken to prevent personal injury or damage to the equipment. Please make sure that you have read and understand these instructions entirely before proceeding with the operation of this unit.

THIS UNIT MUST BE INSTALLED BY THE DEALER THAT YOU PURCHASED IT FROM IN ACCORDANCE WITH THE BLUELINE INSTALLATION PROCEDURES.

PLEASE ENSURE THAT THE WARRANTY CARD IS FILLED OUT BY THE DISTRIBUTOR THAT YOU PURCHASED THIS UNIT FROM AND RETURNED TO BLUELINE.

Record your units serial number here for future reference or if you should need to contact the factory in the future for any reason.

S/N:

This service and operations manual is written specifically for **BLUELINE THERMALWAVE II HP®** Truck Mount Cleaning units manufactured by:

BLUELINE EQUIPMENT LLC

2604 Liberator Drive

Prescott, AZ 86301 USA

The information contained in this document is subject to change without notice and does not represent a commitment on the part of **BLUELINE EQUIPMENT LLC**.

All rights reserved. Copyright 2005 by **BLUELINE EQUIPMENT LLC**. No part of this work may be used or reproduced in any form or means without the express written consent and permission of **BLUELINE EQUIPMENT LLC**.

Published by **BLUELINE EQUIPMENT LLC**.
First printing: MAY 2006
Printed in USA

THERMALWAVE II HP®
MANUAL
PART# 49-025

May-06

LIMITED WARRANTY

BLUELINE warrants your machine to be free of defects in material and workmanship. This warranty shall extend to the designated parts for the specific period of time listed from the date of delivery to the user. If **BLUELINE** receives notice of any defects during the warranty period, **BLUELINE** will either, at its option, repair or replace products that prove to be defective. Any transportation, related service labor, normal maintenance and diagnostic calls are not included.

Gasoline Engine (Through manufacturer or local dealer)	_____	1 year
Vacuum Pump (Through manufacturer or local dealer)	_____	18 months
Water Pump	_____	1 year
Waste Pump	_____	1 year
Engine Heat Exchanger	_____	1 year
Wands (Excluding shut off valve and orifices)	_____	1 year
Waste and Water Tanks	_____	1 year
Pressure Regulator	_____	1 year
Battery (pro-rated)	_____	1 year
All Other Components	_____	1 year

This warranty shall not apply to defects caused by improper installation or operation, inadequate maintenance by the customer, unauthorized modification or misuse, improper repair, freezing or damage due to hard water scaling.

Electrical components, disposable filters, belts, hoses, fittings, o-rings and other service maintenance items are not under warranty. Components supplied by **BLUELINE**, but provided by other manufacturers, will only be warranted to the extent that they are warranted to **BLUELINE**.

To receive warranty service, products must be returned to a **BLUELINE** designated service facility. The customer shall prepay shipping charges for products returned to **BLUELINE** for warranty evaluation and **BLUELINE** shall pay for the return of products to the customer.

BLUELINE makes no other warranty, expressed or implied, with respect to this product. **BLUELINE** disclaims the implied warranties of merchantability and fitness for a particular purpose. Any implied warranty of merchantability or fitness is limited to the specific duration of this limited warranty.

This warranty gives the customer specific legal rights, and you may also have other rights that may vary from state to state, or province to province.

The remedies provided herein are the customer's sole and exclusive remedies. In no event shall **BLUELINE** be liable for any direct, indirect, special, incidental, or consequential damages, whether based on contract, tort, or any other legal theory.

Table of Contents

SECTION ONE: GENERAL INFORMATION	1
1. SAFETY	2
<i>Safety, Specifications, Installation, Fuel, Engine Oil, Chemical, Water Requirements</i>	
2. RECEIVING YOUR TRUCK MOUNT UNIT	7
<i>Dealer Responsibility, Acceptance of Shipment, Equipment Listing, Optional Equipment</i>	
SECTION TWO: INSTALLATION	8
3. INSTALLATION	9
<i>Lifting the Unit into the Vehicle, Positioning the Unit into the Vehicle, Fastening Down the Unit and Waste Tank, Dimensional Diagrams, Installation of Fuel Lines, Trailer Fuel Tank and Fuel Line Installation, Battery Connection, Fire Extinguisher, Console to Waste Tank Connection</i>	
SECTION THREE: OPERATION	14
4. SYSTEMS	15
<i>Water Pumping System, Heat Transfer System, Vacuum System, Chemical System</i>	
5. OPERATION	19
<i>Equipment setup, Instrumentation, Starting Your Unit, Priming the Chemical Pump, Waste Pump, Operation, Cleaning, Upholstery Cleaning, Stair Tool Cleaning, Flood Restoration, Shut Down and Daily Maintenance, Freeze Protection.</i>	
SECTION FOUR: MAINTENANCE and SERVICE	27
MAINTENANCE CHART	29
6. MAINTENANCE	30
7. GENERAL SERVICE ADJUSTMENTS	34
8. TROUBLESHOOTING	37
SECTION FIVE: PARTS and ACCESSORIES	47
9. ILLUSTRATED PARTS LISTINGS	48
10. ACCESSORIES	77

SECTION 1: **GENERAL INFORMATION**

1. SAFETY

Safety	2
Specifications	5
Installation requirements	6
Fuel requirements	6
Engine oil requirements	6
Chemical requirements	6
Water requirements	6

2. RECEIVING YOUR TRUCK MOUNT UNIT

Dealer responsibility	7
Acceptance of shipment	7
Equipment listing	7
Optional equipment	7

1. SAFETY

WARNING For Your Safety!

The following **WARNING** labels are on your **THERMALWAVE II HP®** console. These labels point out important **Warnings and Cautions**, which must be followed at **all** times. Failure to follow warnings could result in personal injury, fatality, to yourself and/or others or property damage. Please follow these instructions carefully! **DO NOT** remove these decals.

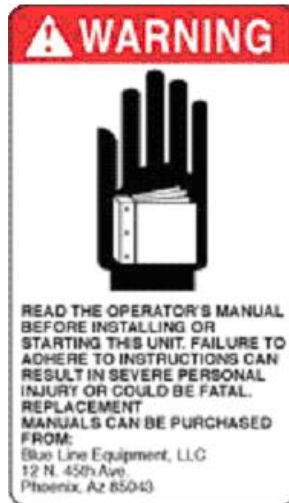

 **WARNING!**

1. Read the operator's manual before starting this unit.

Failure to adhere to instructions could result in severe personal injury or could be fatal.

2. Operate this unit and equipment only in a well-ventilated area.

Exhaust fumes contain carbon monoxide, which is an odorless and deadly poison that can cause severe injury or death. **DO NOT** run this unit in an enclosed area. **DO NOT** operate this unit where the exhaust may enter a building doorway, window, vent or other opening.

3. Gasoline is extremely flammable and its vapors can explode if ignited.

Store gasoline only in approved containers, in well-ventilated, unoccupied buildings and away from sparks or flames. Never carry gasoline or any flammable materials in the vehicle. Fumes could accumulate inside of the vehicle and ignite, causing an explosion.

4. This unit must be operated with the vehicle doors open in order to ensure adequate ventilation to the engine.

5. **DO NOT** operate unit if gasoline is spilled. Do not turn ignition switch until the gasoline has been cleaned up. Never use gasoline for cleaning purposes.

6. **DO NOT** place hands, feet, hair, clothing or any body parts near rotating or moving parts. Rotating machinery can cause severe injury or death.

7. **NEVER** operate this unit without belt and safety guards. High speed moving parts, such as belts and pulleys, should be avoided while the unit is running. Severe injury, fatality or damage may result.

8. **NEVER** service this unit while it is running. High speed mechanical parts as well as high temperature components may result in injury or severed limbs.

9. Engine components will be extremely hot from operation. To prevent severe burns, **DO NOT** touch these areas while the unit is running or shortly after the unit is shut off.

10. **DO NOT** touch any part of the exhaust system while the system is running or for 20 minutes after the unit is shut off. Severe burns could result.

11. **Water under high pressure at high temperature can cause burns, severe personal injury, or fatality.** Shut down unit, allow to cool down and relieve system of all pressure before removing caps, valves, plugs, fittings, filters or hardware.

12. **NEVER** leave the vehicle engine running while the unit is in operation.

13. **Battery acid contains sulfuric acid.** To prevent acid burns, avoid contact with skin, eyes and clothing. Batteries also produce explosive hydrogen gases while charging. To prevent fire or explosion, charge batteries only in a well ventilated area. Keep sparks, open flames, as well as other sources of ignition away from battery at all times. Remove all jewelry prior to servicing batteries. Keep batteries out of the reach of children.

Before disconnecting the negative (-) ground cable, ensure that all switches are in the off position. If on, a spark could occur at the ground connection terminal which could cause an explosion if hydrogen gas or gasoline vapors are present. **ALWAYS** disconnect the negative (-) terminal first.

14. **DO NOT** smoke around the machine. Gas fumes could accumulate and ignite. Battery

SECTION 1

gases are extremely flammable. This will prevent possible explosions.

15. **DO NOT** damage the vehicle in any way during the installation. When routing fuel lines **DO NOT** configure the hose in any locations where the hose or vehicle could be damaged. Avoid contact with moving parts, areas of high temperature, brake lines, fuel lines, catalytic converters, exhaust pipes, mufflers or sharp objects.

16. **NEVER** cut or splice any of the vehicle fuel lines during fuel line installation. This will result in fuel leaks and potentially dangerous conditions. Use only the provided fuel hose for fuel lines. When going through the vehicle floor with fuel lines, always utilize bulkhead adaptors. This will prevent fuel leaks and ensure that hoses are not punctured by vehicle vibration abrasion.

17. **DO NOT** exceed your vehicles weight limit. The console with waste tank and accessories weighs approximately 1420 pounds. Make certain that the vehicle has the correct axle rating. This will prevent unsafe or hazardous driving conditions.

18. High back seats are required for all vehicles that units are to be installed for head and neck protection. Metal partitions between the seats and equipment are strongly recommended.

19. **DO NOT** operate this unit without the water supply on and attached. The water pump and other vital components could be seriously damaged if the unit is operated dry. This unit is equipped with a low pressure shut down switch, which should **NOT** be bypassed.

20. Always keep your vehicle clean and orderly. Wands, tools and accessories must be securely stowed while driving the vehicle.

21. All high-pressure hoses must be rated at 4500 PSI and have a heat rating of 250° F. Thermoplastic hoses do not meet this criteria and should never be used. Severe burns and other injuries could result if hoses do not meet these requirements.

22. Ensure that you have received proper training from the distributor that you purchased the unit from prior to operation.

23. This unit produces high pressure and high temperatures. Improper use could result in serious injury.

24. **DO NOT** modify this unit in any manner. Any modification could result in serious injury or fatality.

25. California Proposition 65 Warning: Engine exhaust from this product contains chemicals known by the State of California to cause cancer, birth defects, or other reproductive harm.

SPECIFICATIONS

Engine Speed	2400 rpm (High speed dual wand.) 1900 rpm (Medium speed single wand.) 1500 rpm (Low speed upholstery.) 900 rpm (Idle.)
Water Pump RPM	1550 rpm
Vacuum Pump RPM	2660 rpm @ 525 cfm
Water Flow Rate	5 GPM (maximum)
Water Pump Pressure	3000 PSI (maximum)
Vacuum Relief Valve	13 in. HG
Waste Tank Capacity	90 Gallons at shutoff
Console Weight	1060 lbs.
Console Weight (with waste tank & accessories)	1420 lbs. (2220 lbs w/full waste tank)

TORQUE VALUES

Engine Hub	720 inch/lbs. 60 ft/lbs.
Vacuum Pump Hub	192 inch/lbs. 16 ft/lbs.

JET SIZING

BLUELINE recommends that the total floor tool tip size does not exceed .06". Using larger jet sizes on your **THERMALWAVE II HP®** unit may reduce cleaning temperatures.

Example: Four-jet wand uses four 95015 jets. (95 deg. Spray angle w/015 orifice)
 $.015 \times 4 = .06$

When using two wands while cleaning with this unit, **BLUELINE** recommends that the tip size in each tool does not exceed a total of .040".

Example: Four-jet wand uses four 9501 jets. (95 deg. Spray angle w/01 orifice)
 $.01 \times 4 = .04$ $.04 \times 2 \text{ tools} = .08$

Upholstery tool jet size: 80015

Stair tool jet size: 9502

Spray Lance Jet Size: 3.5 GPM Maximum

of cleaning chemicals, which will result in greater efficiency in lower concentrations.

2. RECEIVING YOUR TRUCK MOUNT UNIT

DEALER RESPONSIBILITY

THE **BLUELINE** DEALER THAT YOU PURCHASED THIS TRUCK MOUNT CLEANING UNIT FROM IS RESPONSIBLE FOR THE PROPER INSTALLATION OF THIS MACHINE. THE DEALER IS ALSO RESPONSIBLE FOR THE PROPER INITIAL TRAINING OF YOUR OPERATORS AND MAINTENANCE PERSONNEL.

ACCEPTANCE OF SHIPMENT

Your **THERMALWAVE II HP®** truck mount cleaning unit was thoroughly tested, checked and inspected in its entirety prior to leaving our manufacturing facility. **When receiving your unit, please make the following acceptance check:**

1. The unit should not show any signs of damage. If there is damage, notify the common carrier immediately.
2. Carefully check your equipment and packing list. The standard **BLUELINE THERMALWAVE II HP®** unit should arrive with the following items as well as any optional accessories:

EQUIPMENT LISTING

- A. **BLUELINE THERMALWAVE II HP®** console.
- B. Operation and Service manual.
- C. Installation mounting plates and bolt down kit.
- D. Hose clamps for vacuum and fuel hoses.
- E. Carpet wand.

- F. Waste tank with shutoff switch and filters.
- H. Pre-Filter box and stainless steel strainer basket.
- I. 150 ft. of 1/4 in. high pressure solution hose with quick connects.
- J. 150 ft. of 2 in. vacuum hose
- K. 2 vacuum hose connector.
- L. 50 ft. water supply hose with quick connect.

OPTIONAL EQUIPMENT

- A. Additional lengths of vacuum hose
Part # 18-003
- B. Additional vacuum hose connectors
Part # 21-003
- C. Additional high-pressure solution hoses
Part # 18-000
(With shutoff valve Part # 18-001)
- D. Automatic waste pump kit
Part # 68-003
- E. Demand pump system
Part # 68-002
- F. KIT, FUEL HOOKUP CHEVY 97 TO 2002. FI
Part # 69-003FI
- G. KIT, FUEL HOOKUP CHEVY/DODGE FI
Part # 69-004FI
- H. KIT, FUEL HOOKUP FORD FI
Part # 69-005 FI
- I. KIT, FUEL HOOKUP 2003 CHEVY FI
Part #69-018FI
- J. KIT, 2004 TF ADAPTER CHEVY
Part # 69-032
- K. KIT, 2004 TF FUEL INJ. CHEVY
Part # 69-033
- L. ADAPTOR, 2004 FORD FUEL
Part # 69-041
- M. ADAPTOR, 2004 FUEL INJ. FORD
Part #69-041FI

SECTION 2: **INSTALLATION**

3 INSTALLATION

Lifting the unit into the vehicle	9
Positioning the unit into the vehicle	9
Fastening down the unit and waste tank	9
Dimensional diagrams	10
Installation of fuel lines	12
Trailer fuel tank and fuel line installation	12
Battery Connection	12
Fire extinguisher	12
Console to waste tank connection	13

3. INSTALLATION

WARNING!!!

This unit must be bolted to the floor of the vehicle by an authorized BLUELINE DISTRIBUTOR.

LIFTING THE UNIT INTO THE VEHICLE

The BLUELINE THERMALWAVE II HP® weighs approximately 1420 lbs., a forklift is necessary to place the unit into the vehicle. Place the forks into the forklift slots from the front of the unit and make **CERTAIN** that the forks are spread to the maximum width of the unit.

POSITIONING THE UNIT INTO THE VEHICLE

Vehicles vary in size and openings. Owners have different preferences on where in the vehicle they want their units positioned. BLUELINE strongly recommends a side door installation for the THERMALWAVE II HP®. We **DO NOT** recommend a rear door installation.

1. Ensure that enough space is provided to assure adequate engine ventilation as well as room for service and maintenance.
2. The complete unit with waste tank and accessories **MUST NOT** exceed the vehicle's axle weight limit.
3. **NEVER** position the console closer than 12 inches from the bottom rear of the driver and passenger seats.

FASTENING DOWN THE UNIT AND WASTE TANK

CAUTION!!!

Prior to drilling any holes in the vehicle floor, ensure that while drilling, you will not damage the fuel tank, fuel lines, or any other vital components, which could affect the safety and or operation of the vehicle.

A. The console and waste tank mounting holes will serve as a template. Drill six (6) 13/32 in. diameter holes for the console and six (6) 13/32 in. diameter holes for the waste tank.

B. Using the provided mounting hardware kit:

1. Insert six (6) 3/8-16 x 2 ½ in. hex head cap screws with flat washers through the THERMALWAVE II HP® console mounting holes, and six (6) 3/8-16 x 2 in. hex head cap screws with flat washers through the waste tank mounting holes.
2. Install the provided mounting plates underneath the vehicle floor.
3. Screw the provided 3/8-16 hex head lock nuts on to the mounting bolts and tighten until the console and waste tank are firmly attached to the vehicle floor.

DIMENSIONAL DIAGRAM REAR MOUNT TANK

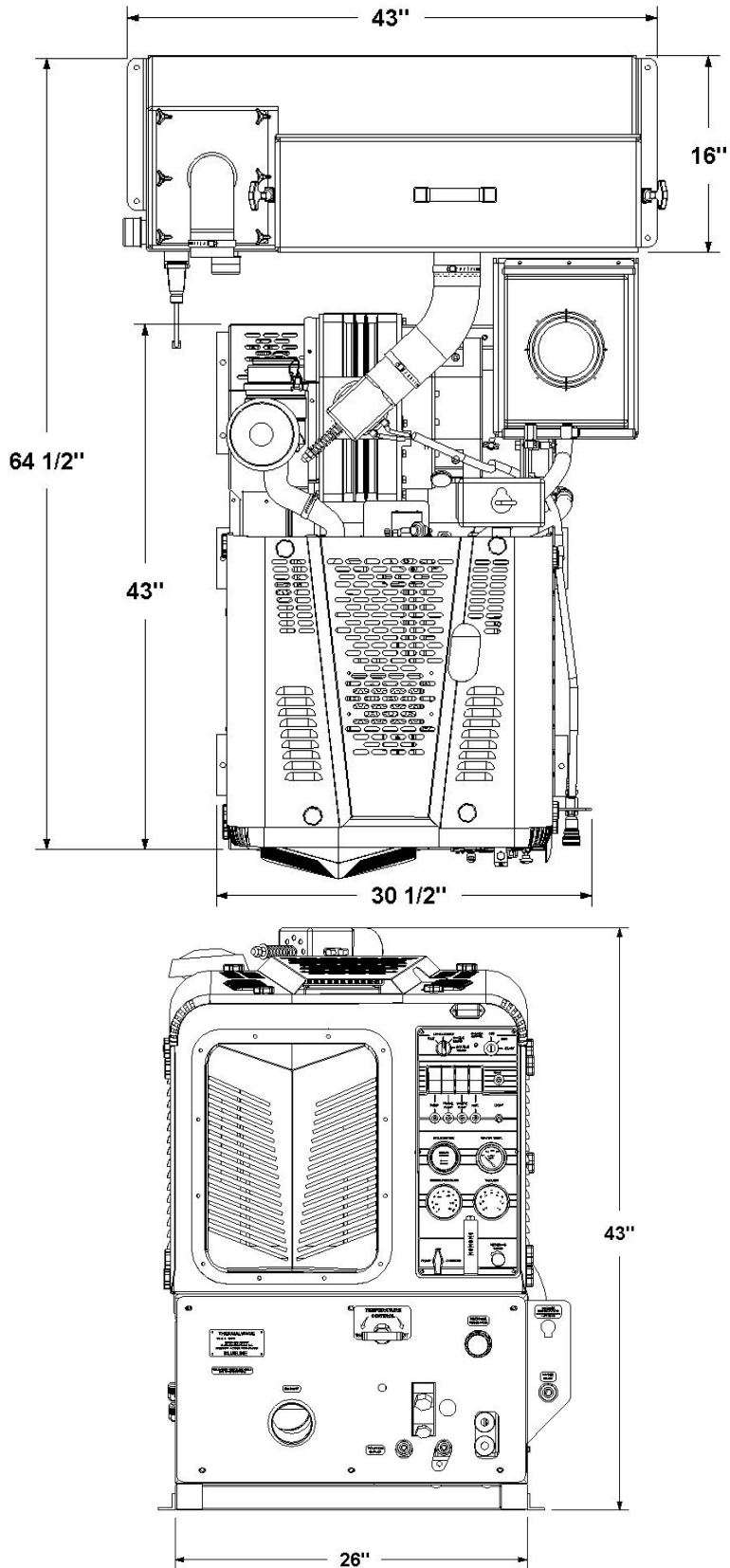

DIMENSIONAL DIAGRAM w/ SUB-MOUNT WATER TANK

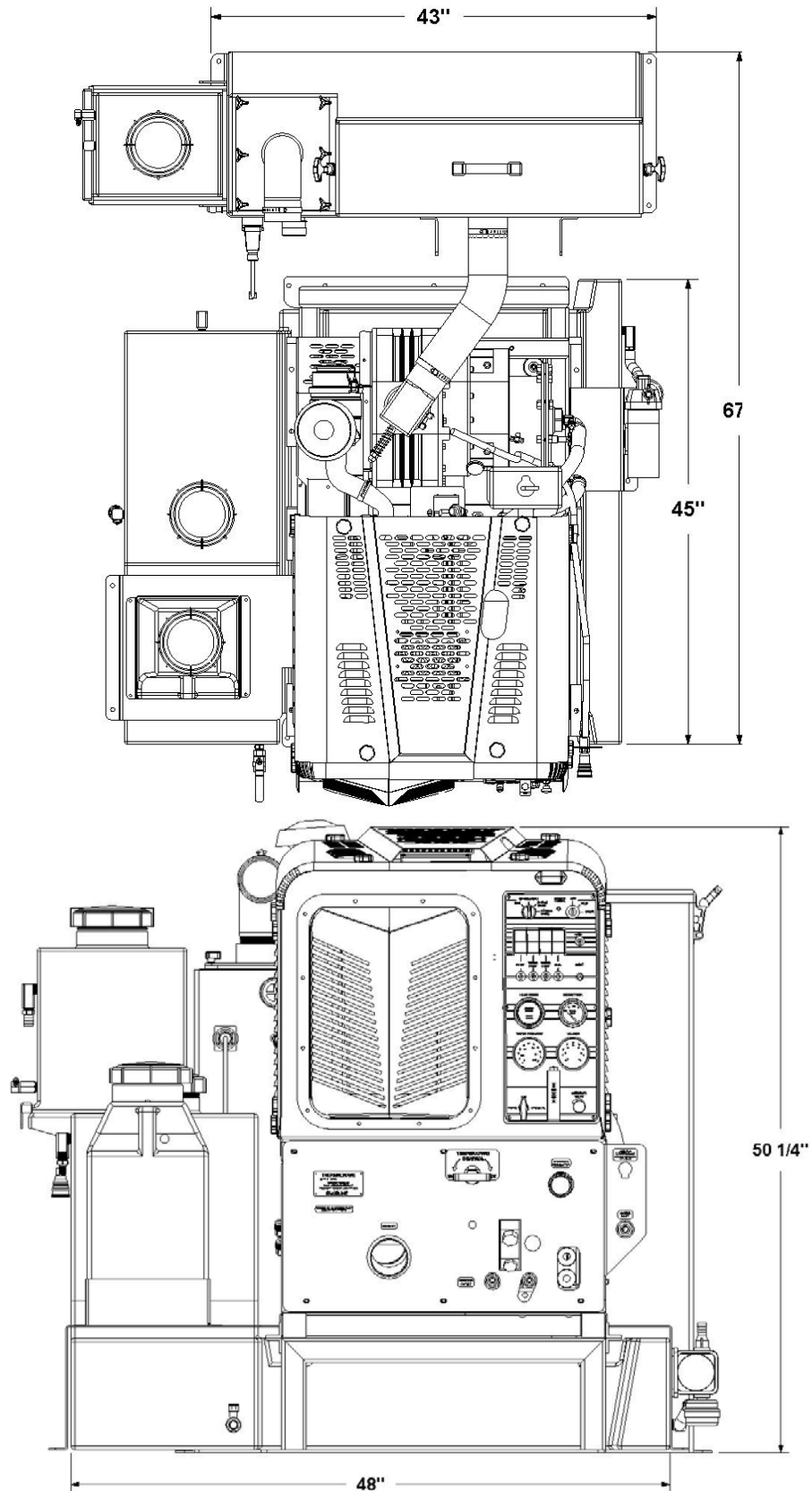

INSTALLATION OF FUEL LINES

CAUTION!!!

READ THESE INSTRUCTIONS IN THEIR ENTIRETY PRIOR TO PROCEEDING.

WARNING!

The Vehicle fuel lines should NOT be spliced under ANY circumstances. Severe injury or fatality could result.

DO NOT damage the vehicle in any way during the installation. When routing fuel lines **DO NOT** configure the hoses in any location where the hoses or vehicle could be damaged. Avoid contact with moving parts, areas of high temperature, brake lines, fuel lines, catalytic converters, exhaust pipes, mufflers or sharp objects.

TRAILER FUEL TANK AND FUEL LINE INSTALLATION

The following are recommendations for trailer installations:

- A. Strict compliance with all federal and state laws must be maintained.
- B. Use only fuel tanks that are manufactured specifically for gasoline, have proper vented filling caps, and outlet connections that are the same size as the inlet and return connections on the unit.
- C. **DO NOT** install fuel tanks inside any type of enclosed trailer or vehicle.

WARNING!

NEVER carry gasoline or flammable materials in an enclosed trailer or vehicle.
NEVER store any type of flammable material in an enclosed trailer or vehicle.

D. Always mount fuel tanks where they will be protected from any vehicle collision.

E. When installing fuel lines from the fuel tank to the unit, use the proper size fuel line.

BATTERY CONNECTION

WARNING!

Explosive gases, Dangerous gases! Batteries contain sulfuric acid. To prevent acid burns, avoid contact with skin, eyes and clothing. Batteries also produce explosive hydrogen gases while charging. To prevent fire or explosion, charge batteries only in a well ventilated area. Keep sparks, open flames, as well as any other sources of ignition away from batteries at all times. Remove all jewelry prior to servicing batteries. Keep batteries out of the reach of children.

Before disconnecting the negative (-) ground cable, ensure that all switches are in the OFF position. If ON, a spark could occur at the ground connection terminal, which could cause an explosion if hydrogen gas or gasoline vapors are present. ALWAYS disconnect the negative (-) terminal first.

A. Attach the red positive (+) battery cable from the starter solenoid on the console to the positive (+) terminal on the battery and tighten down the nut.

B. Attach the black negative (-) battery cable from the ground on the console to the negative (-) terminal on the battery and tighten down the nut.

FIRE EXTINGUISHER

BLUELINE, and many government agencies, recommend that a fire extinguisher rated for A, B, and C type fires be installed into any commercial vehicle.

CONSOLE TO WASTE TANK CONNECTION

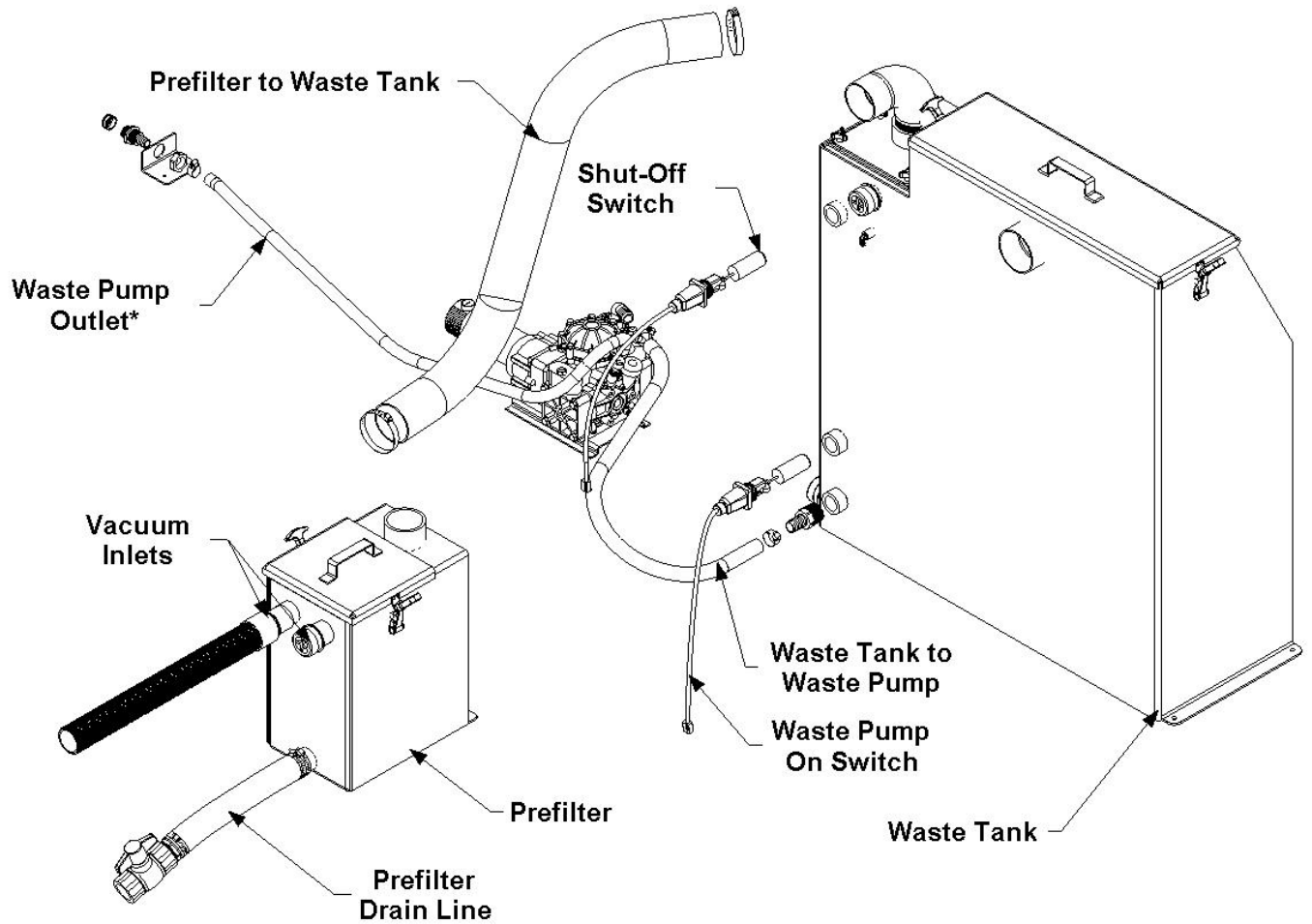

*Shown with optional waste pump out kit #68-003.

SECTION 3: **OPERATION**

4. SYSTEMS

Water pumping system	15
Heat transfer system	16
Vacuum system	17
Chemical pumping system	18

5. OPERATION

Preparation	19
Starting the unit	21
Priming the chemical pump	22
Automatic waste pump	22
Operation	22
Cleaning	23
Upholstery cleaning	23
Stair tool cleaning	23
Flood restoration/extraction	23
Shut down and daily maintenance	23
Freeze protection	24

4. SYSTEMS

NOTE: Read and understand this section of the manual entirely before proceeding.

This portion of the manual divides the unit up into systems and describes how each system works. Prior to proceeding into the operations and maintenance sections of this manual it is recommended that you acquire a basic understanding of how the unit functions.

WATER PUMPING SYSTEM

See figures 3-1 and 5-10. Cold water enters the console through the water inlet connection located on the lower right corner of the right lower front panel. The water then flows to the water box through a float valve, which shuts off the water when the water box is full.

Water then flows through a strainer in the water box to the water pump. The water pump is plumbed to a nitrogen charged accumulator, which helps reduce pressure pulsations. The water pump assembly also includes a high-pressure and a low-pressure shutdown switch. These switches will shut down the unit if the water pressure exceeds 3000 PSI or drops below 50 PSI for more than 5 seconds.

Simultaneously, water is then pumped to the pressure regulator assembly, which provides and maintains the desired pressure setting.

Water then flows from the pressure regulator through the engine coolant heat exchanger and into the blower exhaust heat exchanger, where it is super-heated by the blower exhaust.

The water then flows through the check valve manifold that contains a Y-strainer and a check valve. At this point, the chemical injection takes place.

The hot solution mixture of water and chemicals then flows through the solution outlet manifold to the cleaning tool.

Temperature is controlled with the temperature control valve. Water temperature is maintained by mixing cooler water from the water box with heated water from the engine coolant heat exchanger and the blower exhaust heat exchanger.

SECTION 3

HEAT TRANSFER SYSTEM

See figures 3-1 and 5-10. Water is heated through a 2 stage heat exchange system that utilizes engine coolant and blower exhaust.

Stage one utilizes hot engine coolant pumped through a shell containing stainless steel coils. The pressurized water flows through the coils and

collects heat from the engine coolant. The water then flows to the second heat exchange system.

The second heat exchange system is a blower exhaust heat exchanger, containing a stainless steel heating coil. Water flows through the coil and collects heat from the blower exhaust as it leaves the blower.

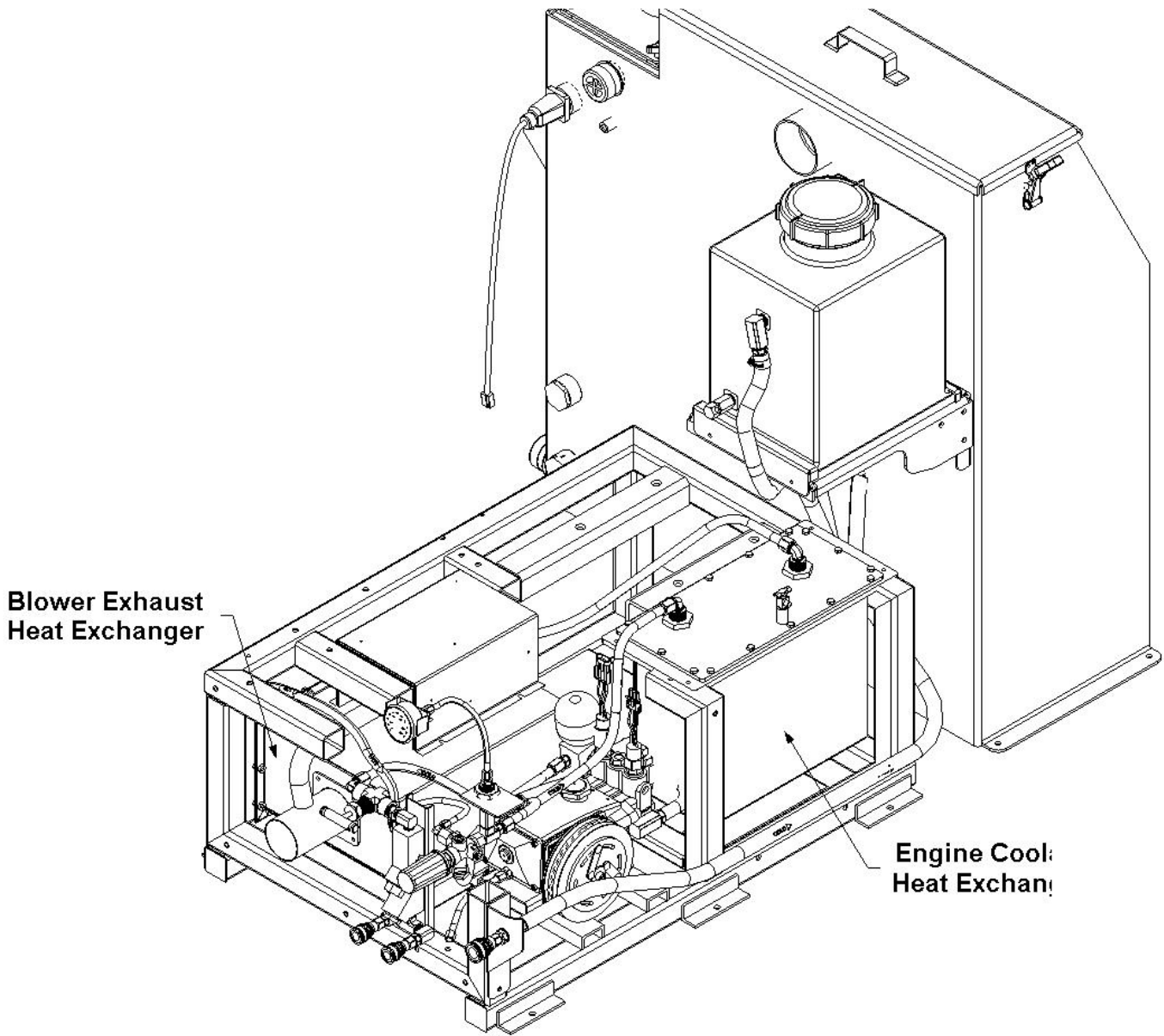

3-1

VACUUM SYSTEM

See figures 3-2 and 5-20. The vacuum flow is initiated by the vacuum pump, or blower. An air and water mixture is drawn into the vacuum inlet on the pre-filter box. The mixture flows through a strainer basket in the pre-filter box, and then into the waste tank. The air exits the waste tank through a 100 mesh filtration system, into the vacuum pump. A vacuum pump relief valve is installed for vacuum pump protection.

The air is discharged from the vacuum pump through a spiral silencer, and then through the vacuum pump exhaust heat exchanger.

A level shut off sensor is located near the top of the waste tank and will shut down the unit before the tank is at full capacity. This protects the vacuum pump from water damage. **Note:** Waste tank level shut off will not shut the unit off due to high levels of foam. The use of a quality defoamer is recommended.

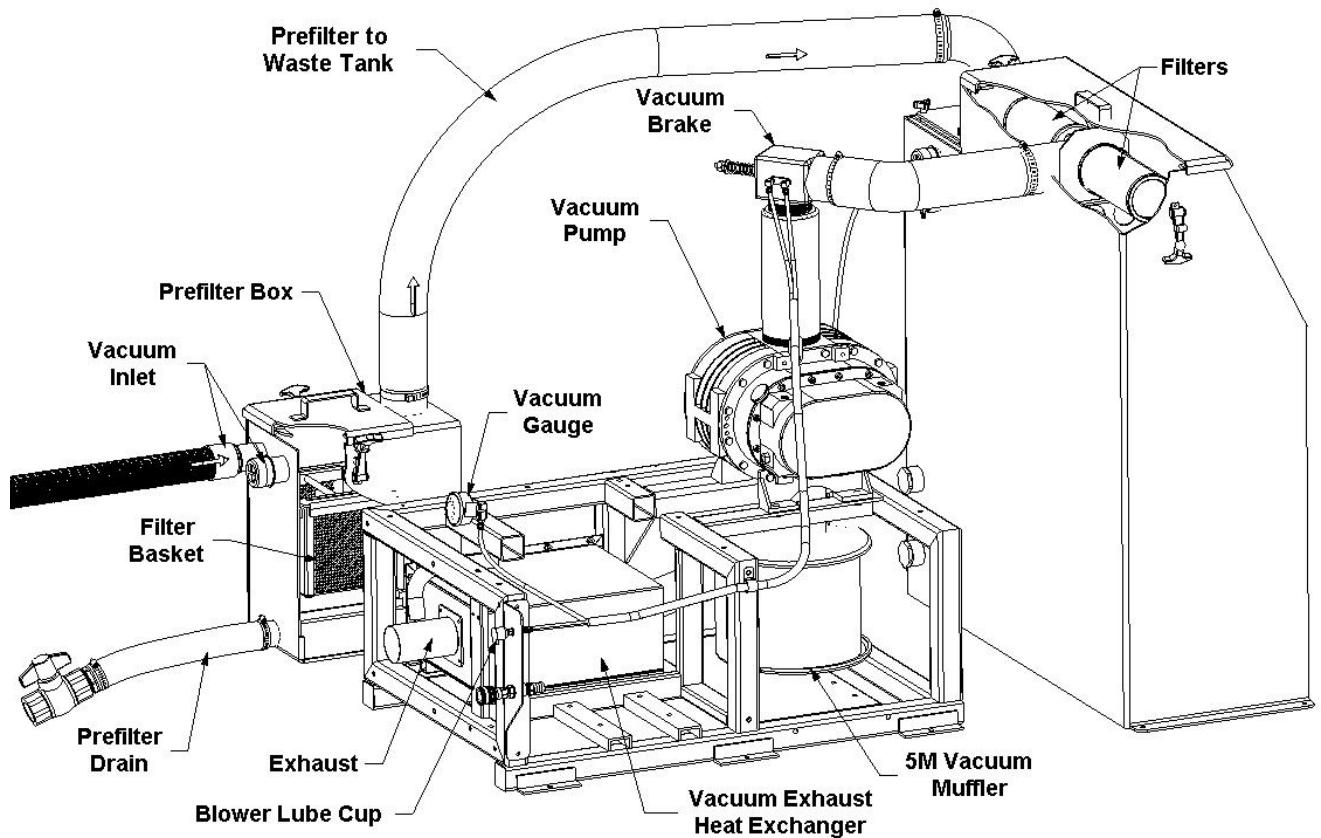

3-2

CHEMICAL PUMPING SYSTEM

See figures 3-3 and 5-25. The chemicals are drawn from the chemical jug through a strainer into the flow meter. The flow meter indicates the rate of chemical flow.

The chemicals then flow through the chemical metering valve to the solution outlet. This valve controls the rate of flow of chemical into the cleaning solution, which is indicated on the flow meter.

The chemicals then flow through the check valve into the stainless steel pulsation chemical pump. Then, the chemical pump injects the chemicals through the check valve to the three way selector valve located on the front panel. This valve may be used to turn the chemical flow **ON**, **OFF**, or to **PRIME** the chemical pump.

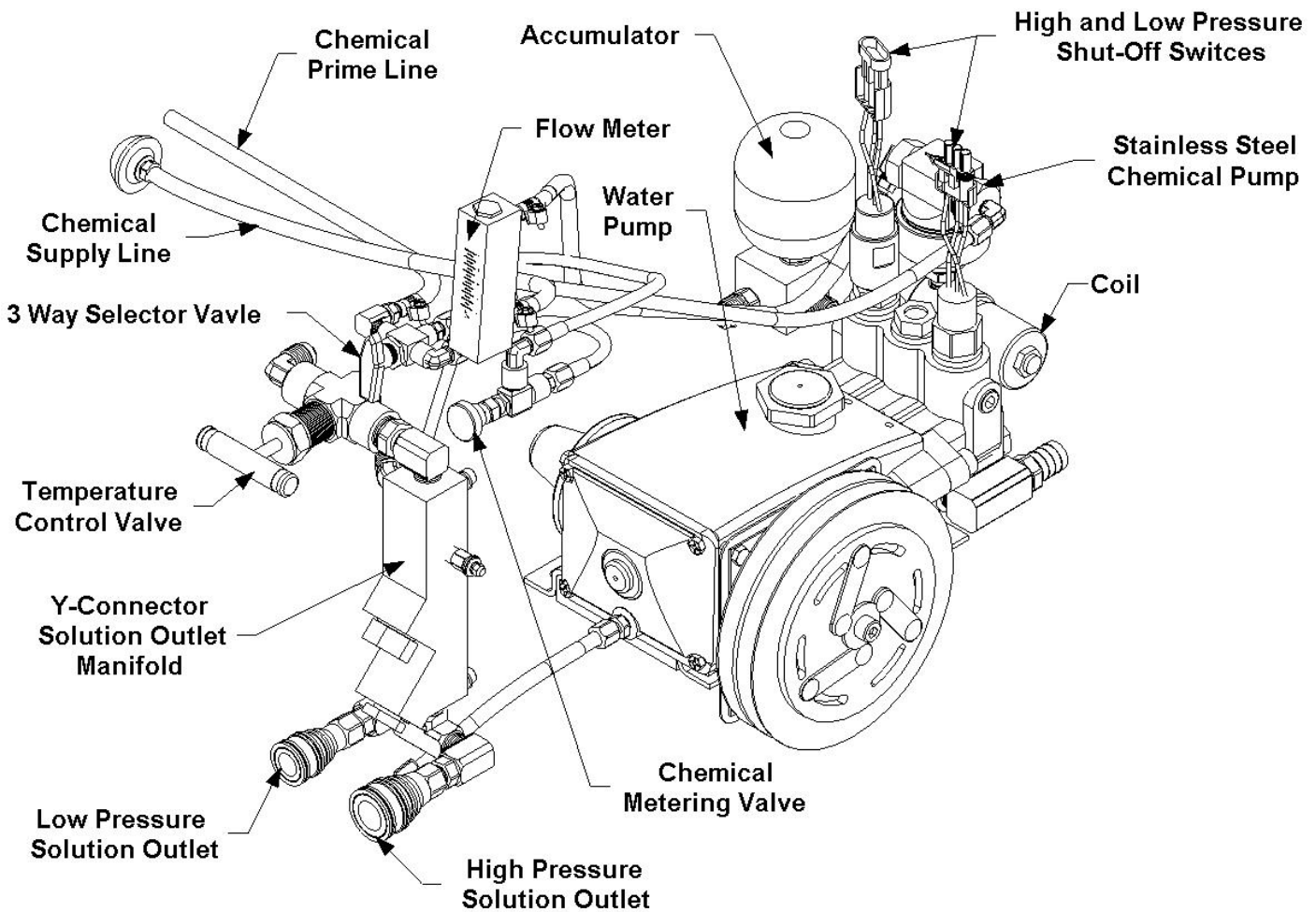

3-3

5. OPERATION

PREPARATION

This section of the operator's manual explains how to prepare, start, operate, shut down and maintain your **BLUELINE THERMALWAVE II HP®** mobile cleaning unit. The **THERMALWAVE II HP®** unit is easy to operate, however only trained operators should proceed.



Operate this unit and equipment only in a well ventilated area. Exhaust fumes contain carbon monoxide, which is an odorless and deadly poison that can cause severe injury or death. **DO NOT** run this unit in an enclosed area. **DO NOT** operate this unit where the exhaust may enter a building doorway, window, vent or any other opening.

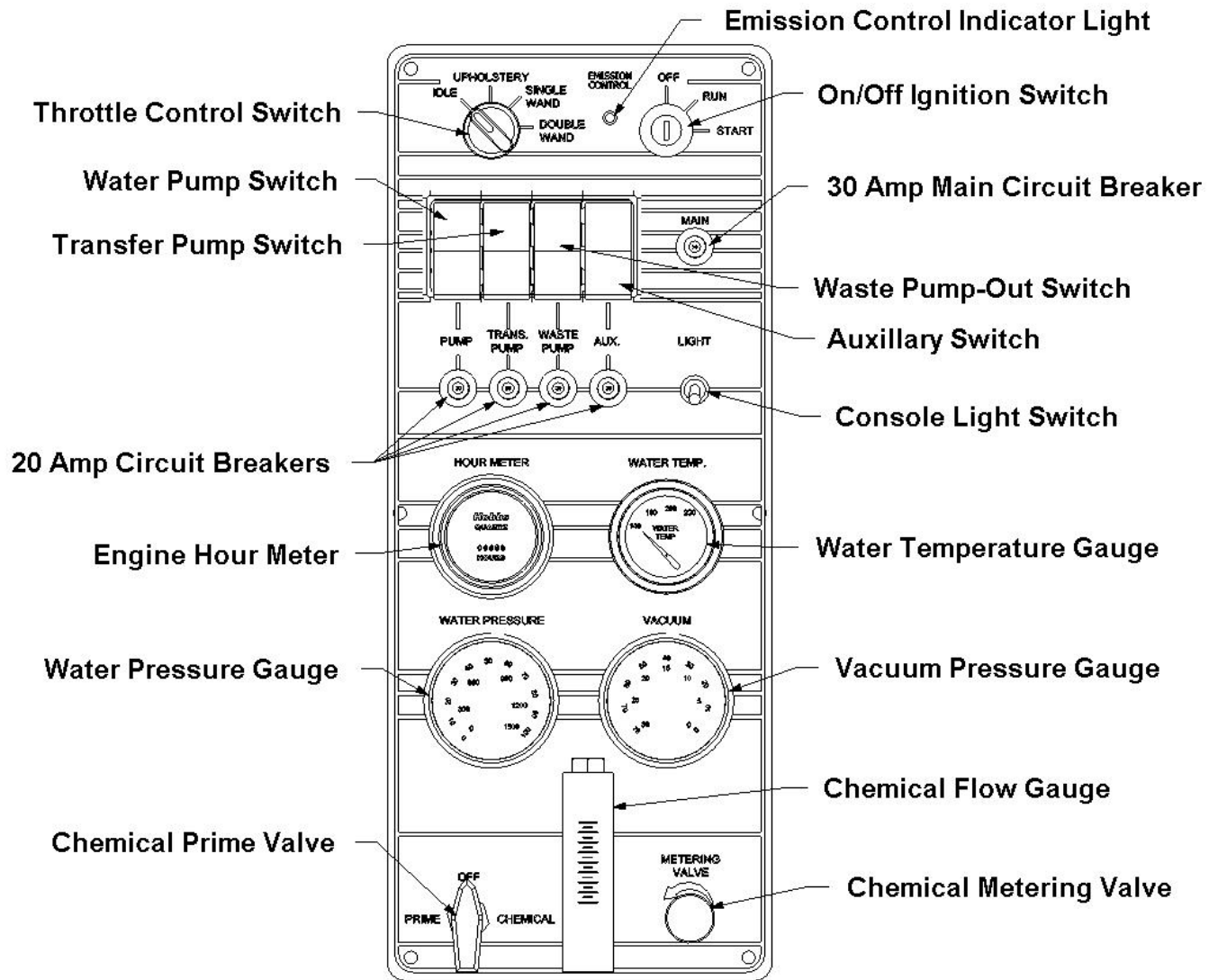

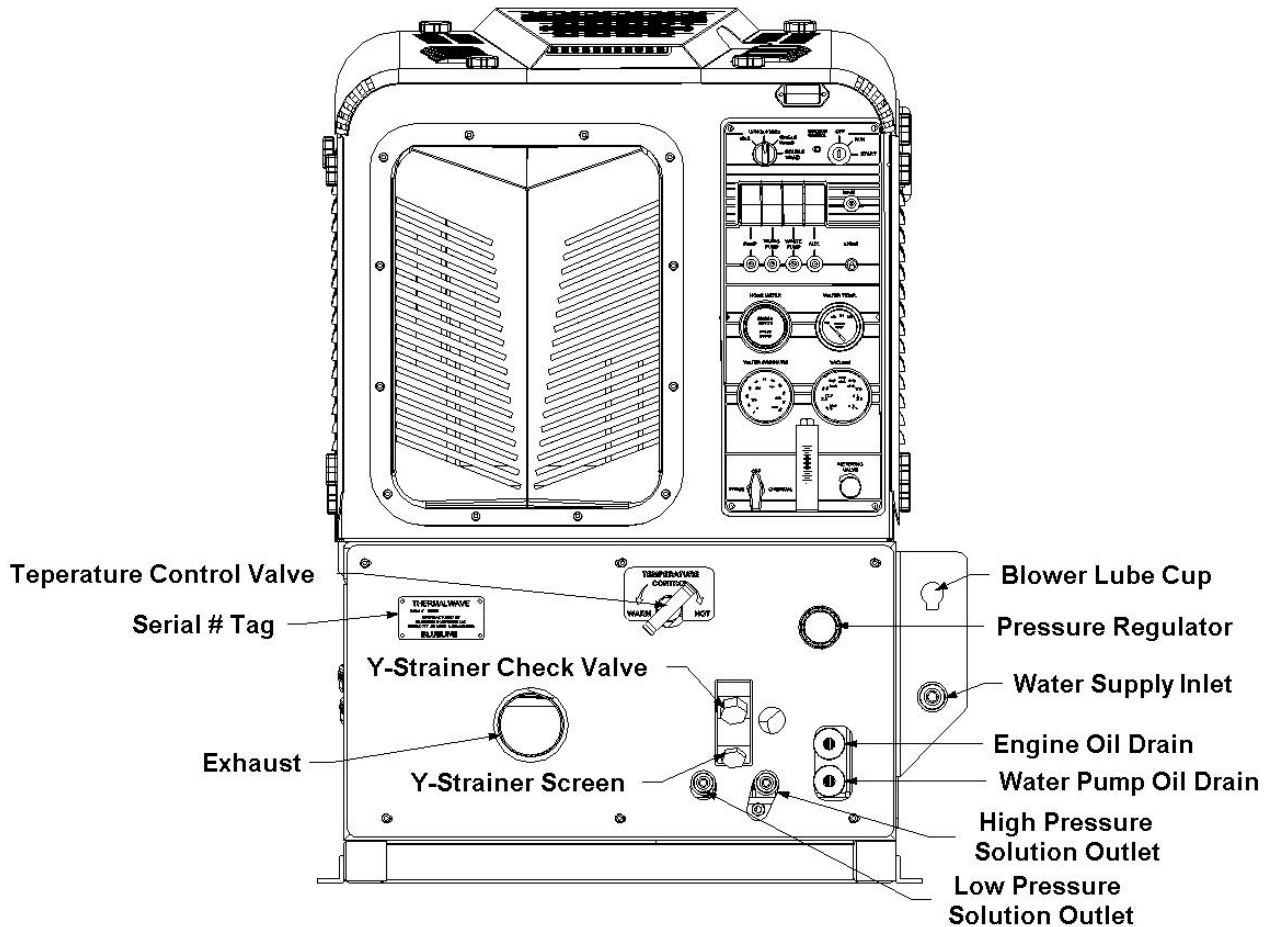

ENSURE THERE IS ADEQUATE FUEL

Check the fuel tank to ensure there is adequate fuel to complete the job and transport the vehicle. This unit consumes approximately 1.2 to 1.8 US gallons of fuel per hour, depending on the speed setting.

REMOVE TOOLS FROM THE VEHICLE

Remove any tools, accessories or hoses from the vehicle that you will require.

WATER SUPPLY CONNECTION

NOTE: Prior to connecting your water inlet hose to any supply faucet, flush out the faucet until the water is free of any debris. Also, flush out any debris from your water inlet hose.

1. Connect the water supply hose to the water inlet quick connector on the front of the unit. Connect the hose to the faucet.

NOTE: Never use a waste pump outlet hose as a water inlet hose. Use only clean hoses for water supply.

2. Turn the water supply faucet on. Water will fill the water box.

HIGH PRESSURE HOSE

Before starting the unit, connect the high pressure hoses to the solution outlet connection(s) at the front of the unit. Connect the cleaning tool(s) to the opposite end of the pressure hose(s).



VACUUM HOSE

Connect the vacuum hose(s) to the vacuum inlet connection(s) at the front of the pre-filter box. Connect the opposite end of the vacuum hose(s) to the cleaning tool(s).

JET SIZING

BLUELINE recommends that the total floor tool size does not exceed “.06”. Using larger jet sizes on your **THERMALWAVE II HP®** unit may reduce cleaning temperatures.

Example: Four-jet wand uses four 95015 jets. (95 deg. Spray angle w/015 orifice)
 $.015 \times 4 = .06$

When using two wands while cleaning with this unit, **BLUELINE** recommends that the tip size in each tool does not exceed a total of “.04”.

Example: Four jet wand uses four 9501 jets. (95 deg. Spray angle w/01 orifice)
 $.01 \times 4 = .04$
 Upholstery tool jet size: 80015.
 Stair tool jet size: 9502

Spray Lance Jet Size: 3.5 GPM Maximum

STARTING THE UNIT

CAUTION!

DO NOT operate this unit without constant water flow to the console.

The low-pressure switch will automatically shut down the unit if the water pressure in the system drops below 50 PSI, for more than 5 seconds.

The high-pressure switch will automatically shut down the unit if the water pressure in the system exceeds 3000 PSI, for more than 5 seconds.

This unit features a computerized fuel system. This eliminates the need for a choke cable and many other troublesome components.

1. Set the speed selector switch to the idle position.
2. Turn the ignition switch to the right intermediate position. Hold the switch in this position for approximately 3 seconds, allowing the fuel pump to pump fuel.
3. Turn the ignition switch to the furthest right position. This will engage the starter and start the engine. The engine will run at a high rate of RPM for a short period of time, then find its proper idle setting.
4. After the engine is running at its idle setting, select the desired speed setting using the throttle control switch.
5. Turn the water pump switch to the **ON** position.

NOTE: If the unit does not build water pressure after 5 seconds, check for adequate water supply. See “Loss of Water Pump

Pressure in the “**Troubleshooting**” section of this manual.

Allow adequate time for the water temperature to warm up before cleaning, approximately 10-15 minutes.

PRIMING THE CHEMICAL PUMP

NOTE: BLUELINE recommends that the chemical pump be primed whenever the water pump is on. This eliminates possible pressure fluctuations and water pump pulsations related with running the chemical pump dry.

1. Insert the chemical prime tube and the chemical inlet tube into the chemical jug.

NOTE: When inserting the chemical tube into the chemical jug, ensure that it stays fully submerged, as the chemical pump will not function if air is allowed to enter the inlet line. **DO NOT** operate the chemical pump without the inlet strainer properly installed.

2. Turn the 3-way chemical selector valve located on the control panel to the **PRIME** position. The chemical will then flow from the chemical jug through the chemical prime tube.

If the pump does not prime, then:

A. Place the chemical prime tube into the vacuum hose and seal off the vacuum hose. The vacuum will quickly draw chemical from the chemical jug. After the flow begins, turn the chemical selector valve to **OFF** position, insert the chemical prime tube back into the jug, and turn the chemical selector valve back to the **PRIME** position and continue the procedure.

B. Once chemical flow with no air bubbles has been achieved, turn the chemical

selector valve from **PRIME** to **METER**. With the cleaning tool open, check the flow meter and adjust the chemical metering valve until the desired rate of chemical flow is achieved.

AUTOMATIC WASTE PUMP

1. If your unit is equipped with an optional automatic waste pump, connect one end of the 5/8 inch or larger garden hose to the pump-out connection and the other end to an acceptable waste disposal.

2. Turn the pump-out switch located on the front console control panel to the **ON** position. The waste pump will now operate automatically throughout the cleaning period.

DO NOT use an outlet hose that is smaller than 5/8 in. I.D.

NEVER use a waste pump hose as a water inlet hose.

WARNING!

NEVER dispose of waste water in a storm drain, water way or on ground areas. Always dispose of waste in accordance with Local, State and Federal laws.

OPERATION

After you have completed the previous steps, proceed with the cleaning operation. Place the throttle control switch to the desired cleaning mode for carpet, or upholstery cleaning. A float shut-off switch is located inside of the waste tank. It will automatically shut down the unit if the tank reaches its full capacity. If this occurs, empty the waste tank before continuing.

CLEANING

While cleaning, observe the following guidelines:

1. Before cleaning, ensure that the wand nozzles are functioning properly.
 - A. Hold the wand approximately one foot above the surface to be cleaned and open the wand valve. A full even spray should emit from the cleaning nozzles.
 - B. If the nozzles are not showing a full even spray pattern, adjust, clean, or replace the nozzles, if required.
2. Usually, chemical solution is applied during the push stroke of the wand during cleaning, and extraction is done on the pull stroke. For heavily soiled carpets, the wand may be used in a scrubbing action, with chemical solution applied in both push and pull strokes, provided that the final stroke is a pull stroke with no chemical injection.

UPHOLSTERY CLEANING

1. Upholstery tools have a lower flow rate and smaller orifices. To accommodate the desired cleaning temperature, operate the unit in the **upholstery** mode, by setting the throttle control switch on the front control panel to **upholstery**. Adjust the temperature control valve to the desired temperature. To maintain proper cleaning temperatures, make certain that the unit has been fully heated up prior to cleaning.
2. Always clean upholstery with a pressure setting below 300 PSI, by using the pressure regulator on the unit.

STAIR TOOL CLEANING

1. Set the throttle control switch on the front control panel to the **CARPET** setting. Adjust the temperature control valve to the desired temperature. To maintain proper cleaning temperatures, make certain that the unit has been fully heated up prior to cleaning.

FLOOD RESTORATION/EXTRACTION

CAUTION!

1. Set the throttle control switch on the front control panel to the desired setting. Make certain that the **water pump switch** is in the **OFF** position. Proceed into the extraction process. **NOTE:** It may be necessary to activate water pump during prolonged operation in flood restoration/extraction to ensure adequate engine cooling.

SHUT DOWN AND DAILY MAINTENANCE

1. Flush out the chemical system with fresh water to remove any chemical residue.
2. Remove as much moisture from the vacuum hoses as possible. This will prevent spillage of wastewater in your vehicle when returning hoses.
3. Disconnect the vacuum hoses from the front of the pre-filter box.
4. Turn the throttle control switch to the **IDLE** position.
5. Adjust the temperature control valve to the cold water position.

SECTION 3

6. Allow the unit to run for at least **2 minutes** or until the water temperature is at or below 180 deg. F. This will also remove any moisture from the vacuum pump.

NOTE: If shutting down for the day: Plug the vacuum inlets on the front of the unit and set the throttle switch to **carpet**. Spray WD-40 (or equivalent) into the **blower lubrication cup**, located above the vacuum inlets for **5 seconds**. This will lubricate the vacuum pump. Next, return the throttle control switch to **IDLE** position, and continue step 4.

7. Turn the ignition switch to the **OFF** position.

8. Turn the water supply faucet off. Loosen the water supply hose at the water supply to bleed off the pressure. Unhook the water supply hose and return it to the vehicle.

9. Activate the valves on all cleaning tools. This will relieve any remaining pressure. Disconnect the cleaning tools and solution hoses and return them to the vehicle.

10. Drain the waste tank, disposing of wastewater in a suitable and proper location.

WARNING!

NEVER dispose of wastewater in a storm drain, water way or on ground areas. Always dispose of waste in accordance with Local, State, and Federal laws.

11. Remove the strainer basket from the pre-filter box. Clean out any debris and re-install.

NOTE: Damage may occur to the vacuum pump.

Replacement and maintenance of the filter will prevent rust and corrosion from entering the vacuum pump.

12. Inspect the vacuum inlet filters inside the waste tank **weekly**. Remove and clean the filters if there is any lint or debris present.

NOTE: To remove the vacuum inlet filter, grip the plastic hexagon section of the filter. Gripping the filter by the screen will collapse or destroy the filter. Replace the filter after cleaning until hand tight.

NEVER operate this unit with the filter removed, damaged or improperly installed.

13. At the end of the work day, rinse out the waste tank with fresh water. A deodorizer may be added to prevent bacterial growth.

14. Clean the vehicle interior, unit, tools, hoses etc., as needed. Inspect **ALL** equipment and accessories for any damage, leaks, wear, etc.

FREEZE PROTECTION

CAUTION!

If the unit is exposed to freezing weather conditions, the water inside of the unit may freeze, resulting in SERIOUS DAMAGE to the unit. The following is recommended to prevent this from occurring during the cold weather season:

1. Always park the unit in a heated building when not in use.
2. While out in operation, avoid long periods of shut down as the unit generates heat while running. Keep the unit running just prior to leaving for the next job.
3. If a heated building is not available, winterize the unit with anti-freeze.

It is not possible to winterize units that have auxiliary water tanks. If the unit has

an auxiliary water tank(s), it must be stored in a heated building.

WINTERIZING YOUR UNIT WITH ANTI-FREEZE:

1. Shut off the water supply to the unit and disconnect the water inlet hose from the console.
2. Connect all solution hoses and tools that may have water in them, to the console.
3. Start the unit with the water pump in the **ON** position. Open a tool valve. This will result in the low-pressure switch shutting down the unit when the water box is emptied.
4. Fill the water box with two gallons of 100% glycol based anti-freeze.
5. Start the unit and set the throttle control to the **IDLE** position. Turn the water pump switch to the **ON** position. Open a tool valve until anti-freeze comes out of the tool. Repeat this procedure with **ALL** remaining tools and hoses.
6. After the tools and solution hoses have been filled with anti-freeze, disconnect and store them.

Recover all anti-freeze that comes out of the tools and hoses and store in an approved container. ALWAYS re-use and re-cycle anti-freeze.

7. Prime the chemical injection system with a 100% glycol based antifreeze. Insert the chemical inlet and prime tube into the anti-freeze container. Turn the chemical valve to **PRIME** until anti-freeze comes out of the prime hose. Turn the chemical valve to the **ON** (chemical) position. Ensure that the flow meter indicates flow. Ensure that all anti-

freeze that comes out of the chemical hose goes into an approved container.

After **25 seconds**, turn the chemical valve to the **OFF** position.

8. Adjust the temperature control valve to the cold water position. Allow the unit to run for at least **3 minutes**. The unit is now winterized.

REMOVING ANTI-FREEZE FROM THE UNIT:

1. Connect the solution hoses to the unit, with a tool attached to the opposite end. Start the unit. Turn the water pump on. Open the tool valve and ensure that the anti-freeze goes into an approved container. Allow the anti-freeze to flow into the container until the low-pressure switch shuts the unit down.
2. Fill the water box with fresh water and repeat step 1.
3. Connect the water inlet hose to the unit and turn the water supply on. Connect all tools and solution hoses that were winterized to the solution outlet connections.

Open all tool valves and drain the anti-freeze into an approved container until the water runs clear and all of the anti-freeze is purged from the hoses and tools.

4. Insert the chemical prime hose into the approved container. Submerge the chemical hose into fresh water. Turn the chemical valve to the **PRIME** position until the water runs clear through the prime hose. Remove the prime hose from the container.
5. Turn the chemical valve to the **ON** (chemical) position. This will allow water to flow to the other side of the system.

After all of the anti-freeze has been removed, the unit is ready to operate.

The anti-freeze in your approved storage container will eventually become diluted with water. When the anti-freeze level drops below 70% of the total mixture, properly dispose of it and start over with fresh 100% anti-freeze.



DO NOT drain used anti-freeze on the ground or into storm drains. Dispose of anti-freeze only in an approved location. Observe Local, State and Federal laws when disposing of anti-freeze.

SECTION 4: **SERVICE & MAINTENANCE**

6. MAINTENANCE

Maintenance Chart	29
Engine	30
Vacuum Pump	31
Water Pump	31
Vacuum Inlet Filter	32
Drive Belts, Pulleys and Hubs	32
Water Box / Water Pump Inlet Filter	32
Strainer Basket	32
Y-Strainer (Outlet)	33
Check Valve (Outlet)	33
Chemical Pump, Chemical Metering System	33
Stainless Steel Accumulator	33
Pressure Regulator	33
Vacuum Hoses	33
Battery	33
High Pressure Solution Hoses	34

7. GENERAL SERVICE ADJUSTMENTS

Engine	34
Vacuum Relief Valve	34
Vacuum Pump Drive Belts	34
Water Pump Drive Belt	34
Float Valve	35
Solution Outlet Check Valve	35
Chemical Pump	35
Packing Nut Adjustment, Chemical Metering & Selector Valves	36
Pressure Regulator	36
Adding/Draining Engine Coolant	37

8. TROUBLESHOOTING

Water Pump	38
Chemical System	39
Blower / Vacuum Pump	40
Engine Will Not Start	41
Engine Does Not Crank	42
System Safety Shut Down	43
Z.E.E.M.S.	44
Z.E.E.M.S. Trouble Codes	45
Heating System	46

MAINTENANCE CHART

Engine	Daily	Check engine oil level.** Fill to proper level.
Engine Coolant	Daily	Check coolant level in overflow bottle. Fill to proper level.
Vacuum Pump	Daily	Spray WD-40 (or Equivalent) into the lubrication cup for 5 seconds.
Water Pump	Daily	Check water pump oil level.*** Fill to proper level.
Vacuum Inlet Filter	Daily*	Inspect filter, clean and or replace if required.
Waste Tank Strainer Basket	Daily	Empty and clean stainless steel basket.
Vacuum Hoses	Daily	Rinse with fresh water.
Waste Pump-Out (Optional)	Daily*	Inspect and remove any debris or sediment.
Engine	Weekly	Check air cleaner for damaged, dirty, or loose parts.
Engine	Weekly	Inspect air intake and cooling areas. Clean if required.
Vacuum Pump	Weekly*	Check vacuum pump oil level. Fill to proper level. Do not overfill.
Vacuum Inlet Filter	Weekly	Remove filter and clean.
Water Box	Weekly*	Inspect and clean filter. Replace if damaged.
Battery	Weekly*	Check fluid level. Fill with distilled water only. Do not overfill.
Engine	Monthly	Inspect drive belts for wear. Replace as needed.
Water Box	Monthly	Check float valve for proper operation.
Y-Strainer	Monthly*	Clean and remove any debris.****
High Pressure Solution Hoses	25 Hours	Inspect for wear, damage, or impending rupture. Replace if damaged.
Engine	100 Hours	Change engine oil and filter.
Vacuum Pump	100 Hours	Grease bearings with extreme pressure bearing grease.
Pressure Regulator	100 Hours	Lubricate o-rings. Use only o-ring lubricant part # 13-003.
Battery	100 Hours	Clean battery terminals.
Engine	200 Hours	Check spark plugs and clean if necessary.
Engine	200 Hours	Clean engine air filter.
Chemical Metering System	200 Hours	Inspect packing nut on selector and metering valve. Adjust as needed.
Engine	500 Hours	Change engine coolant.
Engine	500 Hours	Replace in-line fuel filter.*****
Water Pump	500 Hours	Change crankcase oil.***
Pulleys and Hubs	500 Hours	Check pulley and hub set screws for proper torque.*****
Stainless Steel Accumulator	500 Hours	Check pressure. Recharge and change bladder if needed.*****
Engine	1000 Hours	Replace spark plugs.
Vacuum Pump	1000 Hours	Drain, flush, and replace oil.*****
Chemical Pump	1000 Hours	Change diaphragm and check valves. Inspect disk.
Check Valve	1000 Hours	Check Teflon seat for abnormal wear or debris. Replace as needed.
Engine	2000 Hours	Replace air filter element.

To maximize the operating life and performance, use only recommended oils, filters and greases.

*Or as often as required.

Change engine oil and oil filter after **first 50 hours of operation.

***Change water pump crankcase oil after **first 50 hours** of operation

****Inspect after **first week** of operation, and remove any debris present. Inspect again after **2 to 4 weeks**.

*****Check pulley and hub set screws after **first 50 hours** of operation, and again at **100 hours** of operation.

*****Or every **6 Months**. Whichever comes first.

*****Or **Yearly**. Whichever comes first.

4. Clean the engine air filter element every **200 hours**. Replace the element every **2000 hours**.

5. Check the coolant level in the radiator overflow bottle **daily**. If no coolant is present, remove the radiator cap and add coolant. Change the coolant every **500 hours** with a 50:50 coolant to water ratio.

Replace the in-line fuel filter **yearly**.

NOTE: Additional engine service information can be obtained from the provided Nissan Operation and Maintenance manual. If service or repair is required, contact an authorized Nissan Service Center. They will require the serial number of the engine.

VACUUM PUMP

NOTE: Refer to the provided Vacuum Pump Operation and Service Manual for specific instructions.

Lubrication: **BLUELINE** recommends that you use only AEON PD Synthetic Blower Lubricant in the gear end of the vacuum pump for all operating temperatures. AEON PD is formulated specifically for positive displacement blower service to provide maximum blower protection at any temperature. One filling of AEON PD will last a minimum of twice as long as a premium mineral oil.

NOTE: AEON PD (Part # 13-004) is the only oil that **BLUELINE** puts in the vacuum pump at the factory. Adding petroleum oil to synthetic oil is **NOT** recommended.

1. Check the oil level **weekly** to ensure the proper level is maintained. Too little oil will damage and ruin the bearings and gears. Too much oil will result in overheating.

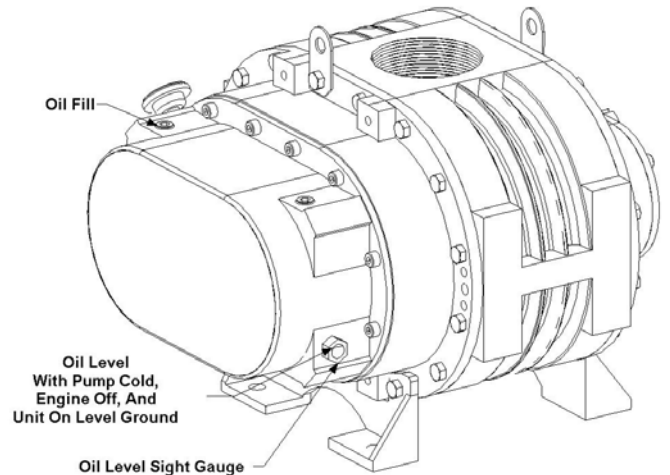

2. A lubrication cup has been provided at the front of the console, to prevent rust from building up inside of the vacuum pump.

Run the unit for at least **2 minutes** to remove any moisture from the vacuum pump. Then, spray WD-40 (or Equivalent) into the lubrication cup for **5 seconds** while the unit is running and the vacuum inlet ports are sealed. This procedure should be done at the end of **every working day**.

3. Drain, flush and replace the oil every **1000 hours or yearly, whichever comes first**.

The bearings on the pulley end of the vacuum pump require grease lubrication every **100 hours**. Grease the bearings until grease comes out of the vent holes on the vacuum pump. Use extreme pressure bearing grease of the spec: NLGI Grade 2 EP (Part # 13-002).

WATER PUMP

Refer to the provided Water Pump Operation Manual for specific instructions.

1. Check the crankcase oil level **daily** to ensure the proper level. If the level has dropped, check for the source of leakage and repair.

SECTION 4

Check pulley set screws and hub screws every **500 hours** thereafter.



Ensure that when you re-torque the screws, you use a clockwise pattern and continue until the proper torque is achieved.

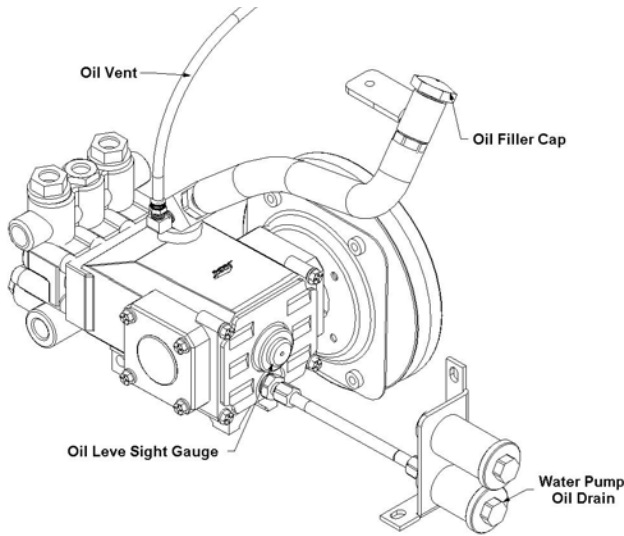

2. After the first **50 hours** of operation, change the crankcase oil with CAT Pump Crankcase Oil, (Part # 13-000). Change the crankcase oil every **500 hours** thereafter.

VACUUM INLET FILTER

1. The vacuum inlet filters in the waste tank should be inspected **daily**, and removed and cleaned **weekly**. The filters will last for a long period of time if this is done.

2. Inspect the vacuum filter inside the waste tank. Remove and clean filter if there is any lint or debris present.



When removing the vacuum inlet filter(s), grip the plastic hexagon section of the filter(s). Grasping filter(s) by the screen will damage or destroy the filter.

DRIVE BELTS, PULLEYS & HUBS

1. Check pulley set screws and hub screws after the first **50 hours** of operation and again at **100 hours**. Re-torque these screws with a torque wrench. Follow the torque values on the following table.

TORQUE VALUES

Component	Inch/lbs	Foot/lbs
Engine Hub	324	27
Vacuum Pump Hub	192	16

2. The **THERMALWAVE II HP®** unit features an Adjustable Belt Tensioning system. This system eliminates the need for sliding the vacuum pump to achieve the proper belt tension. However, belts and pulleys should be checked periodically for wear. They should also be cleaned and inspected regularly. If wear or glazing is discovered, replacement is recommended.

WATER BOX

1. The float valve should be checked at least **monthly** for proper operation. If overfilling is noted, check the plunger for proper seating. Also, check the float rod for proper adjustment.

2. The filter on the bottom of the inside of the water box is produced out of rubber with a stainless steel screen. This filter should be inspected and cleaned on a **weekly** basis, and replaced, if damaged.

NOTE: Prior to removing strainer, vacuum all excess water and debris from water box.

PRE-FILTER BOX STRAINER BASKET

The strainer basket located in the pre-filter box should be emptied and cleaned on a **daily** basis.

Y-STRAINER (OUTLET)

Unscrew the screen and inspect the Y-strainer after the first **week** of operation. Remove any debris present. Inspect again after **2** and **4 weeks**. Thereafter, inspect the Y-strainer and screen at least **monthly**. If a frequent build-up of debris is noticed, inspect and clean more frequently.

CHECK VALVE (OUTLET)

Inspect the check valve when servicing the chemical pump or as needed. Remove the check valve from the Y-strainer assembly and disassemble. Check the Teflon seat for abnormal wear or debris. Replace the Teflon seat if necessary. Improper seating of the check valve poppet, damaged spring, or o-rings will result in poor operation of the chemical system.

CHEMICAL PUMP

The chemical pump should be rebuilt every **1000 hours**. This involves changing the diaphragm, check valves, and inspecting the disk.

CHEMICAL METERING SYSTEM

Check and inspect the packing nut on the chemical selector and metering valves every **200 hours**. Keeping the valve packings properly adjusted will prevent leaks and add to the overall life of the valves.

**STAINLESS STEEL
ACCUMULATOR**

Sealed 250 pound nitrogen accumulator. Change every 2000 hours or as needed.

PRESSURE REGULATOR

Lubricate the o-rings in the pressure regulator every **100 hours**. Use only o-ring lubricant (Part # 13-003).

VACUUM HOSES

To ensure maximum hose life, **BLUELINE** recommends that you wash out the hoses with fresh water **daily**.

BATTERY** WARNING!**

Explosive gases, Dangerous acid!
Batteries contain sulfuric acid. To prevent acid burns, avoid contact with skin, eyes and clothing. Batteries also produce explosive hydrogen gases while charging. To prevent fire or explosion, charge batteries only in a well ventilated area. Keep sparks, open flames, as well as any other sources of ignition away from batteries at all times. Remove all jewelry prior to servicing batteries. Keep batteries out of the reach of children.

Before disconnecting the negative (-) ground cable, ensure that all switches are in the OFF position. If ON, a spark could occur at the ground connection terminal, which could cause an explosion if hydrogen gas or gasoline vapors are present. ALWAYS disconnect the negative (-) terminal first.

1. Check the fluid level in the battery at least **once a week**. If low, fill to the recommended level **ONLY** with distilled water. **DO NOT** overfill the battery. Early failure or poor performance will result due to loss of electrolyte.

2. Keep cables, terminals and external surfaces of the battery clean and dry. A buildup of corrosive

acid or grime on the external surfaces could cause the battery to self-discharge.

3. Battery terminals should be cleaned every **100 hours** to prevent corrosion buildup. Wash the cables, terminals and external surfaces with a mild baking soda and water solution. Rinse thoroughly with fresh water. **DO NOT** allow baking soda to enter the battery cells, as this will destroy the electrolyte, resulting in battery failure.

HIGH PRESSURE SOLUTION HOSES

Inspect your high-pressure solution hoses for wear after the first **100 hours**. Thereafter, inspect every **25 hours**. If the hoses show any signs of damage or impending rupture, replace the hoses.

! WARNING!

NEVER attempt to repair high-pressure solution hoses. Repairing high-pressure solution hoses may result in severe burns and serious injury.

All high-pressure solution hoses must be rated for 4500 PSI at 250 deg. F. Thermoplastic hoses do not meet this requirement and should not be used. Severe burns and injury may result if the hoses do not meet these requirements.

7. GENERAL SERVICE ADJUSTMENTS

! WARNING!

DO NOT attempt to service this unit while it is running. High speed parts as well as high temperature components may result in severe injury, severed limbs, or fatality.

ENGINE

The **BLUELINE THERMALWAVE II HP®** unit features a computerized fuel system. **DO NOT** attempt to service or repair this system without authorization from the factory.

VACUUM RELIEF VALVE

With the unit running at full RPM, block off the airflow at the vacuum inlet ports and read the vacuum gauge. If adjustment is required, shut the unit down and adjust the locking nut tension on the vacuum relief valve. Re-start the unit and read the vacuum gauge. Repeat this process until the vacuum relief valve opens at 13" Hg.

VACUUM PUMP DRIVE BELTS

The **THERMALWAVE II HP®** unit is equipped with an Adjustable Belt Tensioning system. This eliminates the need for sliding the vacuum pump for belt adjustment. Periodic checking of the belts and pulley condition is all that is required.

WATER PUMP DRIVE BELT

To tighten the water pump belt:

1. Loosen the four nuts, which hold the water pump base to the frame.

SECTION 4

2. Adjust the position of the belt tensioning adjusting bolt until the proper belt tension is achieved. (3/4" deflection in the center of the belts, half way between the pulleys).

3. While checking the alignment, tighten the nuts that hold the water pump to the base.

FLOAT VALVE (WATER BOX)

The float valve should only be adjusted if the water box is overflowing or the water level in the water box is low.

1. If the water box is overflowing, remove and check the float valve for damage, or debris. If the float ball has any water inside of it, it must be replaced.



IF replacing the float ball, DO NOT over-tighten the float rod, as it can puncture the ball. Ensure that the nuts are tightened on the rod.

SOLUTION OUTLET CHECK VALVE

Inspect the check valve whenever performing service on the chemical pump or if flow problems are occurring in the chemical system.

1. Remove the check valve, ensuring that the small o-ring on the seat comes out with it
2. Next, remove the seat using a 5/16 in. Allen wrench
3. Check the Teflon seat for wear or debris. Clean and replace the seat if necessary.
4. Inspect the poppet and the spring for wear or damage. Clean and replace as necessary.

5. Re-assemble the check valve. Thread the seat by hand until snug. Then tighten with a 5/16 in Allen wrench. **DO NOT** over-tighten.

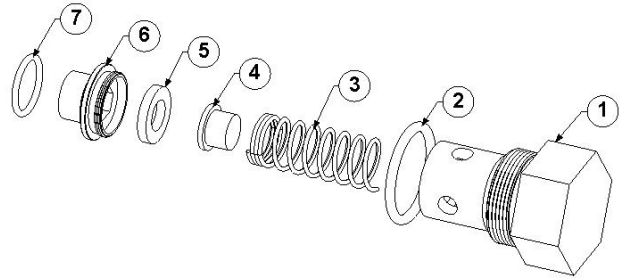

23-023 VLV, CHECK, CHECK VLV MANIFOLD

Item #	Part Number	Qty.	Description
1	27-009	1	CAP, CHECK VALVE ASSY. SS
2	41-007	1	ORING, 7/8 ID X 1-1/16 OD
3	15-004	1	SPRING, CHECK VALVE ASSY.
4	27-010	1	POPPET, CHECK VALVE ASSY
5	27-004	1	INSERT, SEAT-CHK VLV ASSY TM
6	27-011	1	SEAT, CHECK VALVE ASSY.
7	41-008	1	ORING, 1/2 ID 5/8 OD

Note: Improper seating of the check valve seat, poppet, damaged spring or o-rings will result in poor performance of the chemical system.

6. Lubricate the o-rings with o-ring lubricant. (Part # 13-003) and re-install.

CHEMICAL PUMP

The **THERMALWAVE II HP®** unit features a stainless steel chemical pump and metering system. The chemical pump requires only the replacement of the diaphragm and check valves. To replace the diaphragm, unscrew the cover from the body. When replacing the diaphragm, lube the outer edges of the diaphragm with o-ring lubricant (Part #13-003) and reassemble.

To replace the check valves, remove the check valve caps, replace the check valves and

SECTION 4

reassemble using new o-rings. **DO NOT** attempt to reuse o-rings after the check valves have been removed.

HIGH PRESSURE COIL

On a weekly basis check the operation of the high pressure coil located on the water pump, below the stainless steel chemical pump. Prime the chemical pump and increase the pressure using the pressure regulator to 1500 psi. If chemical flow does not stop inspect coil assembly and repair or replace as needed.

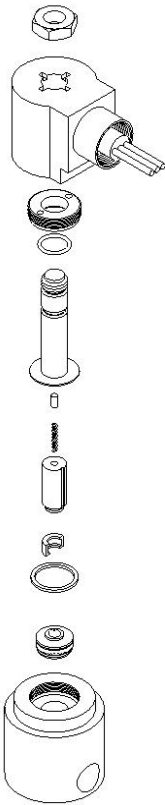

PACKING NUT ADJUSTMENT CHEMICAL METERING/SELECTOR VALVES

Inspect the packing nut for proper tension on the chemical metering and chemical selector valves every **200 hours**. When turning the knob, there should be some resistance. If not, slightly tighten the packing nut. **DO NOT** over-tighten. Keeping

the packing properly adjusted will eliminate possible leaks and will add to the overall life of the valves.

Chemical Prime Valve

Adjust The Packing Nut
By Turning The Packing Bolt
Clockwise In 1/16"
Increments.

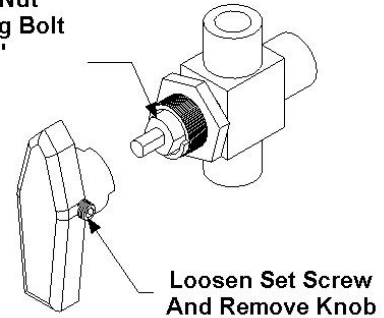

Chemical Metering Valve

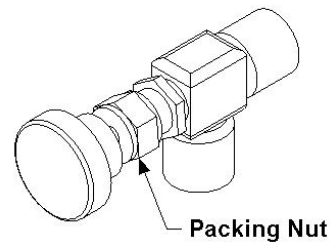

PRESSURE REGULATOR

The pressure regulator holds water pressure at a preset point and bypasses this water back to the water box.

To adjust:

1. With the unit running, close the cleaning tool valve. Check the pressure gauge. Open the tool valve. Set the pressure regulator so that the pressure gauge reads 350 PSI with the tool valve open.

With the tool valve open, there should be a normal drop of approximately 100-PSI, in pressure. **If the drop is greater than 100 PSI, it may be necessary to lubricate the pressure regulator o-rings.**

2. To adjust the pressure regulator, turn the adjusting knob (while observing the pressure gauge on the control panel) until you reach the desired pressure.

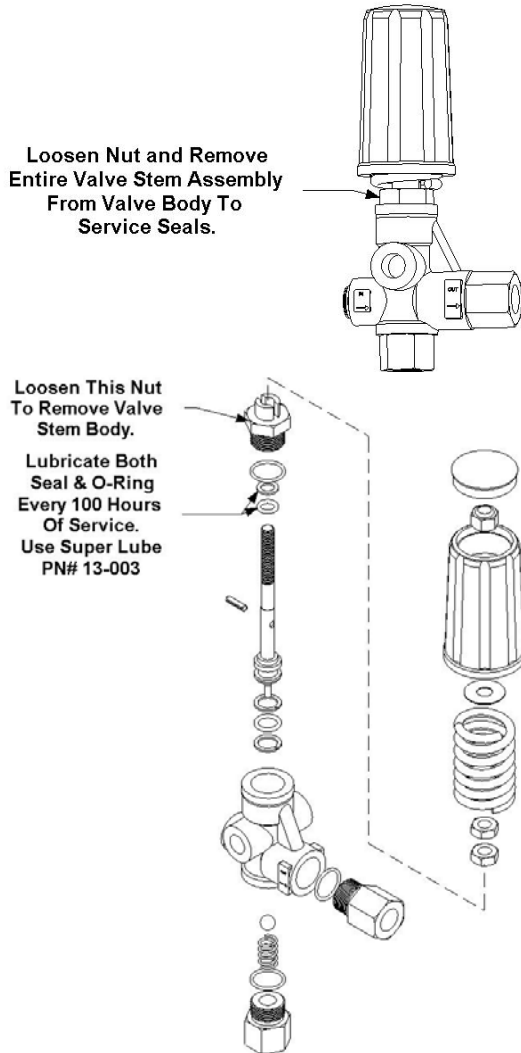

ADDING/DRAINING ENGINE COOLANT

Use a 50:50 coolant to water ratio in this unit's cooling system.

1. To drain the coolant, remove the upper radiator cap and turn the lower radiator draincock counter-clockwise. Open the draincock on the heli-coil

assembly, until drained. **Dispose of anti-freeze only in an approved location**

2. To add coolant, fill the radiator, then bleed the air out of the system by turning the draincock on the heli-coil counter-clockwise. The heli-coil assembly is located on the right hand side of the console while facing the front of the unit. After bleeding the air out of the heli-coil draincock, close the draincock by turning it clockwise. Fill the engine radiator again. Next, fill the overflow container **ONLY** halfway between the "add" and "fill" marks. After running the unit, if necessary, add more coolant to the overflow container only.

8. TROUBLESHOOTING

! WARNING!

DO NOT attempt to service this unit while it is running. High-speed parts as well as high temperature components may result in severe injury, severed limbs or fatality.

This section of the operator's manual describes how to look for and repair malfunctions, which may occur.

Accurate troubleshooting is based on a thorough and complete understanding of the **WATER, CHEMICAL, VACCUM, HEAT TRANSFER, SAFETY** and **WIRING** systems featured in this unit.

If there are malfunctions occurring on this unit which you do not understand, refer back to the **OPERATION** section of this manual and review **SYSTEMS**.

SECTION 4

Water Pump

Note: Make sure the water pump has oil, the water box is full of water and the chemical system is turned off.
 Note: Any time you have a water pump problem, we are actually looking for a water pump volume problem.
NOTE: WATER MAY BE HOT AND UNDER PRESSURE!! EXTREME CAUTION SHOULD BE USED!!

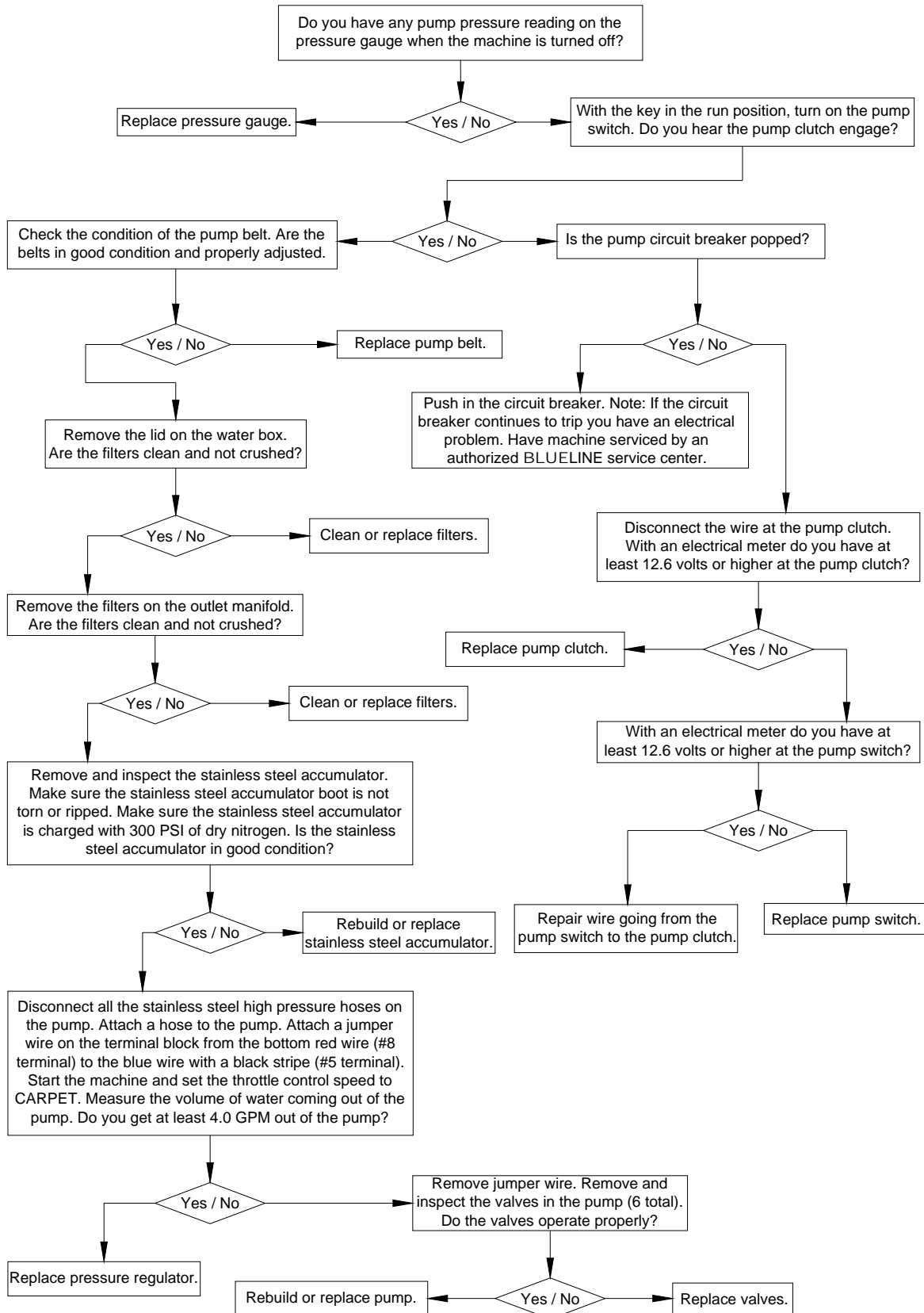

Chemical System

Note: Use a jug with fresh water to diagnose the chemical system.
 Note: If the chemical system works with just fresh water your problem is with your chemicals and not the system.
 Note: Make sure the water pump system is working properly before you proceed.

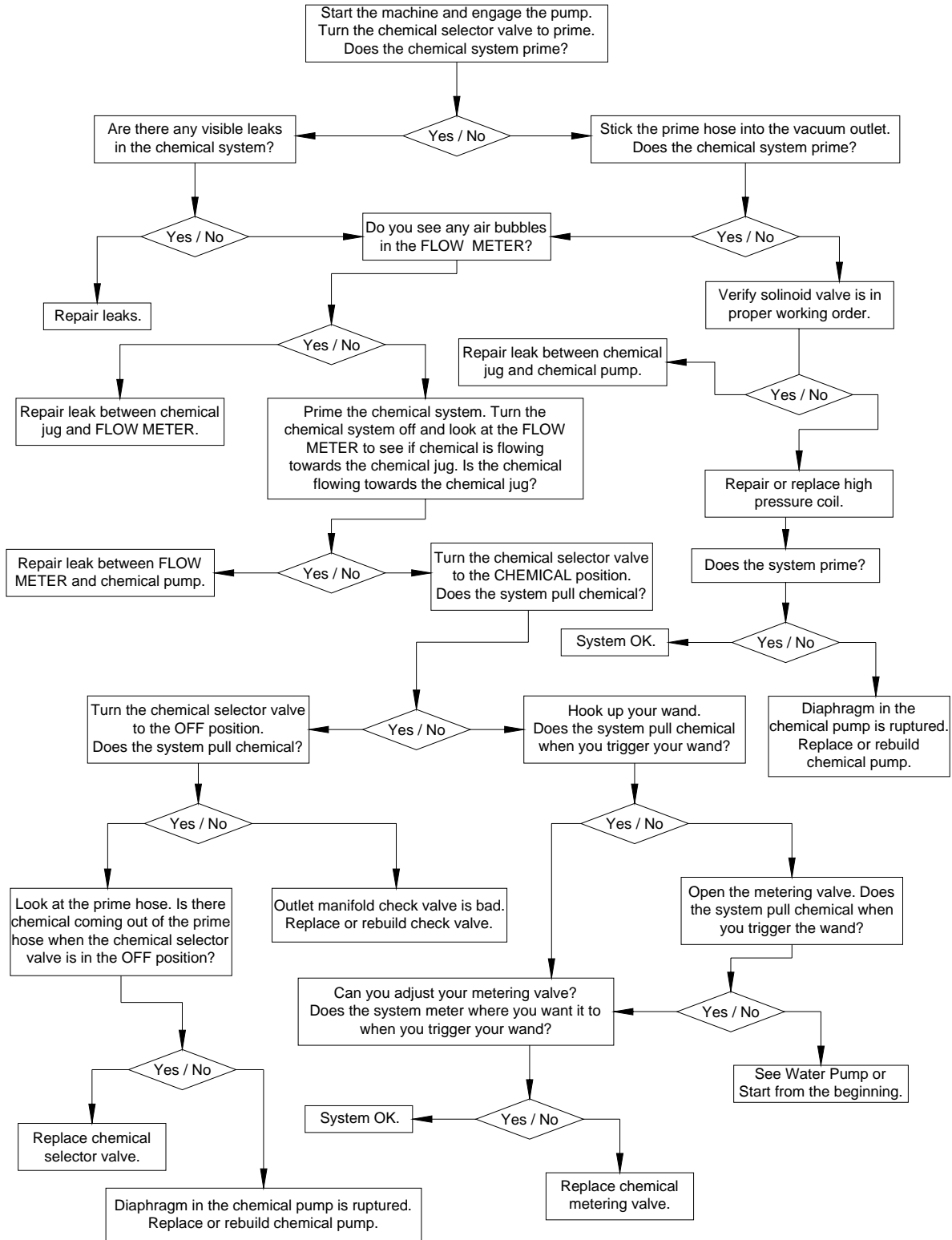

SECTION 4

Blower / Vacuum Pump

Note: Make sure the blower has oil, the waste tank is empty and the waste tank filters are clean and not damaged.
 Note: Any time you have a blower vacuum problem, we are actually looking for an air volume problem.

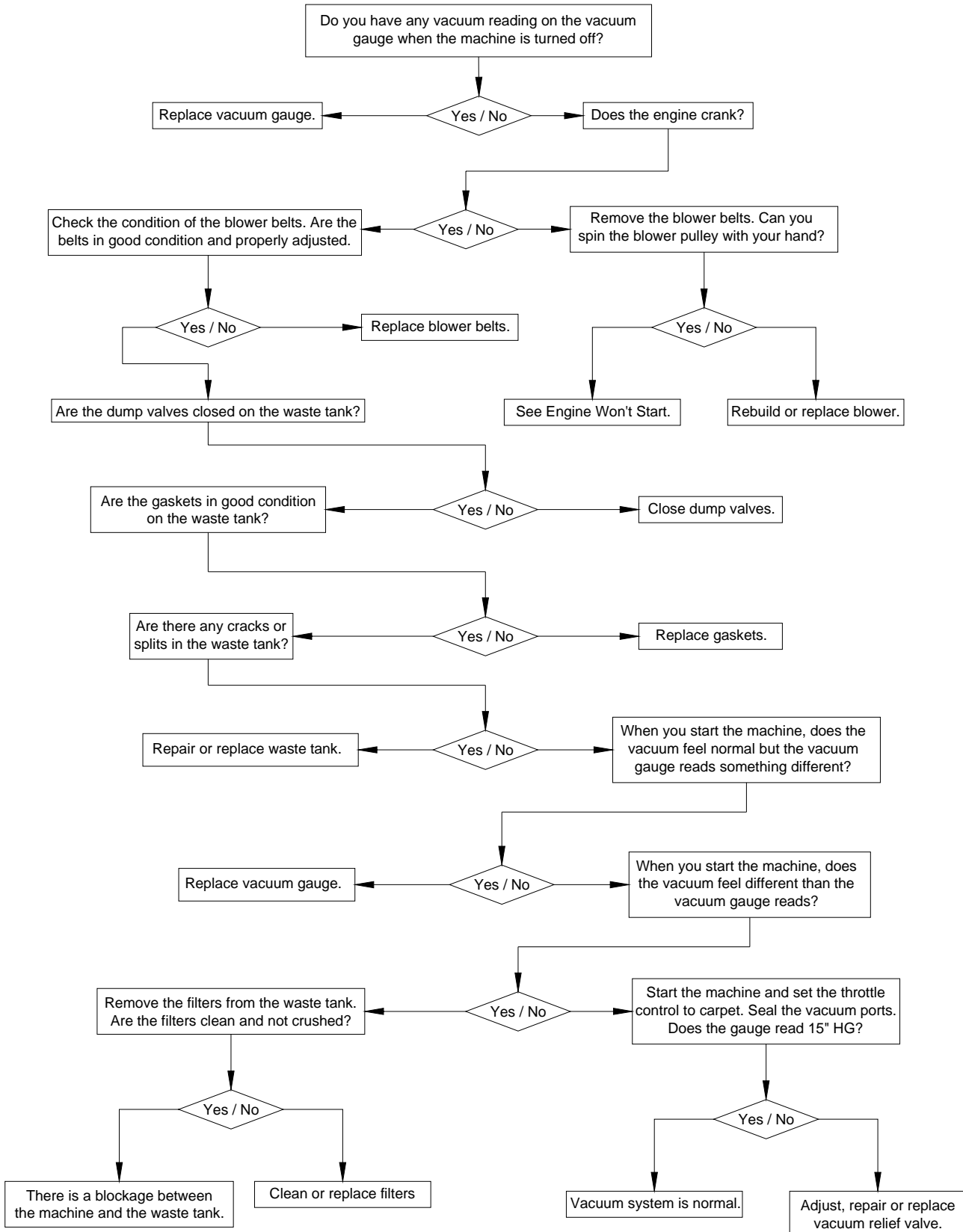

SECTION 4

Engine Won't Start

Note: Make sure the engine has oil, antifreeze, waste tank is empty and you have at least a half tank of gasoline.

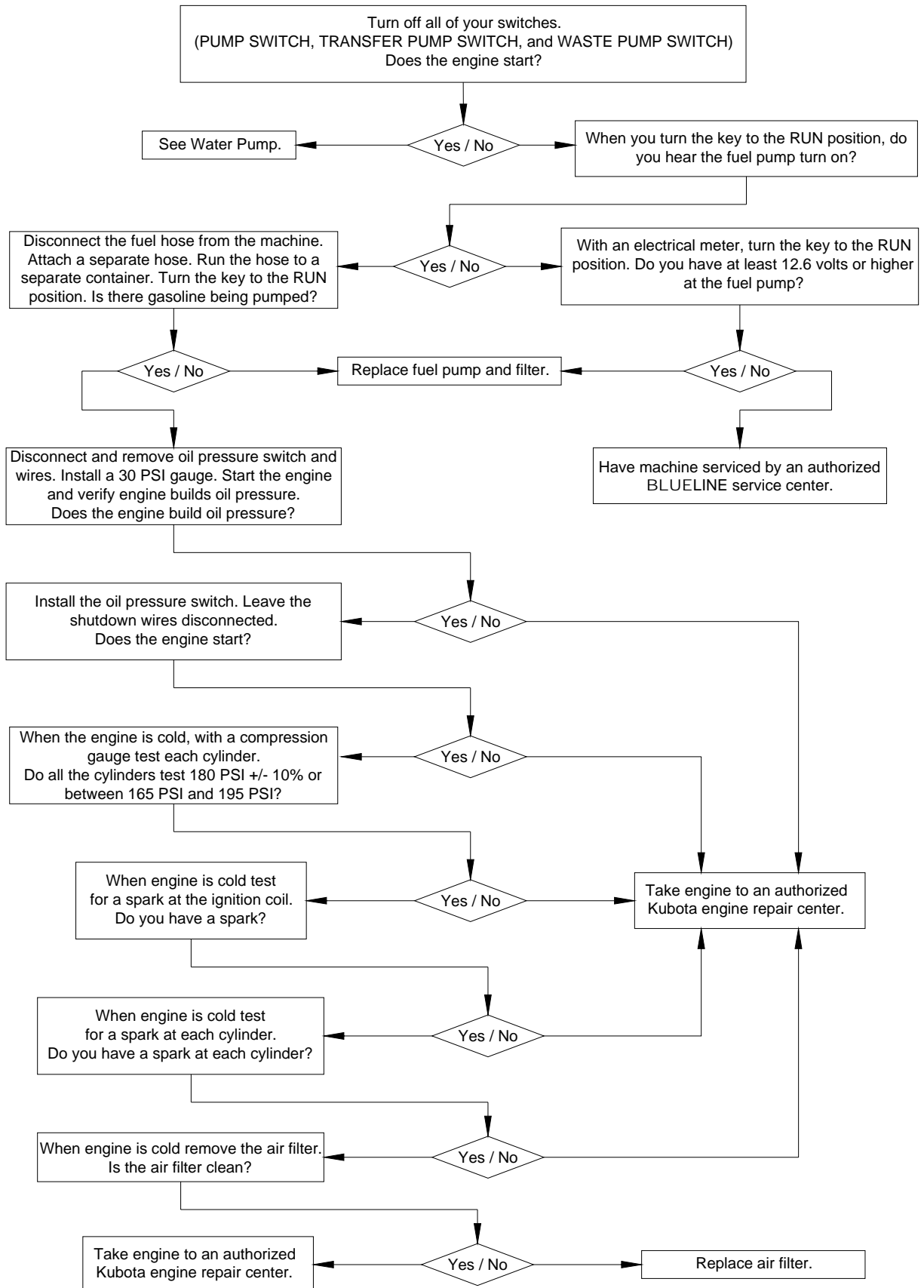

SECTION 4

Engine Does Not Crank

Note: Make sure the engine has oil, antifreeze, waste tank is empty and you have at least a half tank of gasoline.

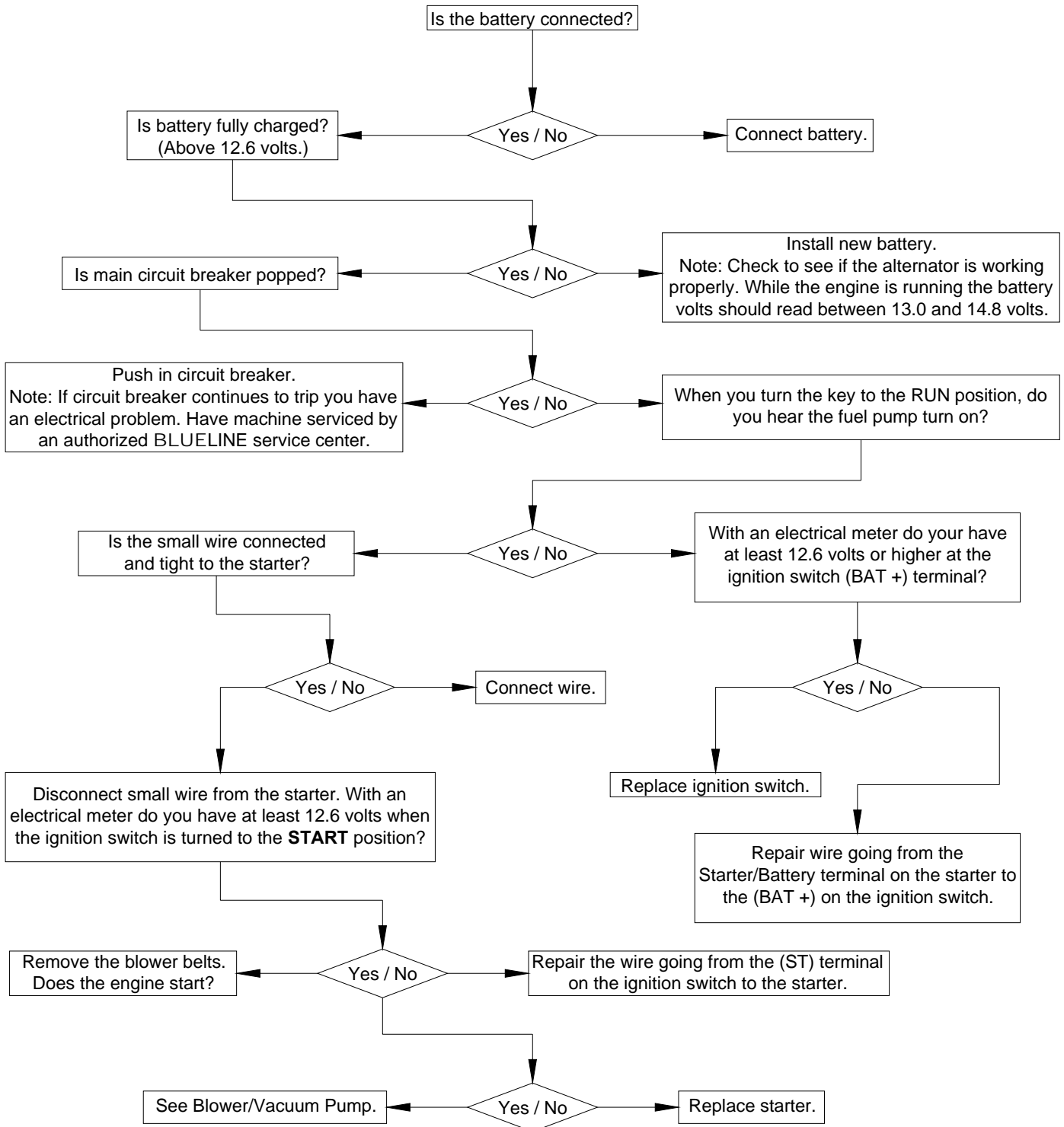

System Safety Shut Down

Note: Your BLUE WAVE console is equipped with various safety shut down systems. If the system shuts down during operation it may be due to one of these safety shut downs.

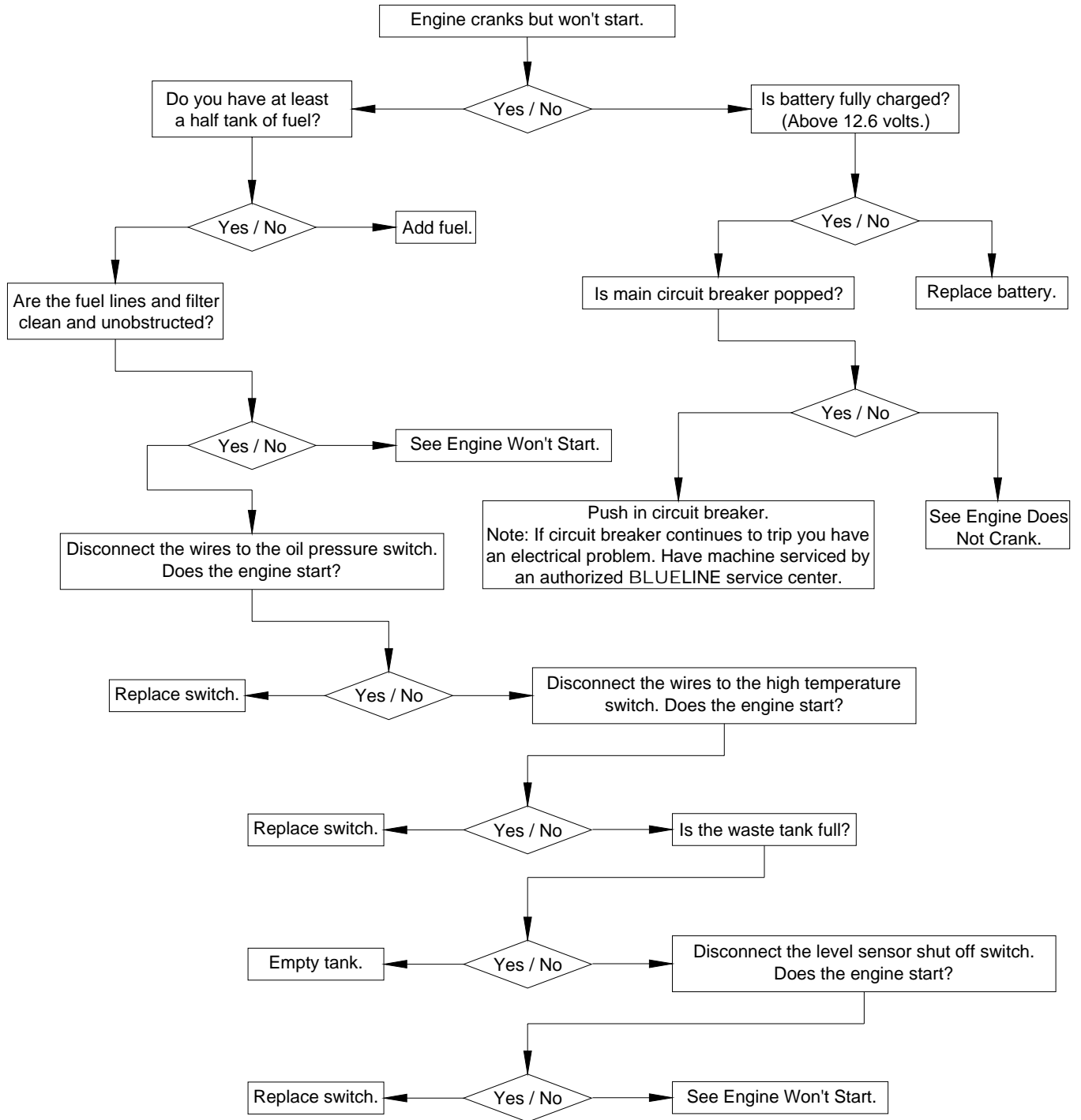

SECTION 4

Z.E.E.M.S.

Note: Fuel may be Under Pressure Extreme Caution Should be used!!!

Have Machine Serviced by an Authorized Blue Line Service Center!

With a Multimeter Ohm (Ω) out the Wiring Harness to see if there are any Shorts or Opens. See Chart Below Does the Wiring Harness check out to be good?

Definition of Terms

ECU	Electronic Control Unit
ECTS	Engine Coolant Temperature Sensor
IATS	Intake Air Temperature Sensor
IMAPS	Intake Manifold Absolute Pressure Sensor
ZEEMS	Zenith Electronic Engine Management System

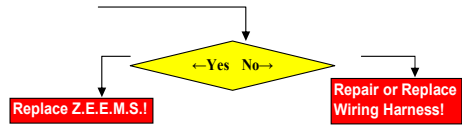

Back side of Connector
Black 23 Pin Connector (Engine Input)

Connector # To Where	Wire Color
1 ECTS	Green
2 Not Used	
3 Not Used	
4 IMAPS	Orange
5 # 3 on Gray 12 Pin Connector	Yellow/Black
6 Not Used	
7 Not Used	
8 Oil Pressure Sensor	Pink
9 IATS	Dark Blue
10 Not Used	
11 IMAPS, ECTS, & IATS	Black
12 Not Used	
13 # 2 on Gray 12 Pin Connector	Red/Black
14 Not Used	
15 # 4 on Gray 12 Pin Connector	White/Black
16 Not Used	
17 IMAPS	Light Green
18 Not Used	
19 Not Used	
20 Not Used	
21 Not Used	
22 Not Used	
23 Not Used	

Back side of Connector
White 23 Pin Connector (Engine Output)

Connector # To Where	Wire Color
1 Not Used	
2 Not Used	
3 Gasoline Injector	Brown
4 # 5 on Gray 12 Pin Connector	Purple
5 Governor Actuator Connector	Gray
6 Not Used	
7 # 6 on Gray 12 Pin Connector	White/Green
8 Not Used	
9 # 9 on Gray 12 Pin Connector	Orange
10 Not Used	
11 Not Used	
12 # 10 on Gray 12 Pin Connector	Red/White
13 Not Used	
14 # 11 on Gray 12 Pin Connector	Dark Blue
15 Gasoline Injector	Red/Black
16 # 7 on Gray 12 Pin Connector	White
17 Not Used	
18 Not Used	
19 Ignition Coil (-) Lead	Light Blue
20 Ground & Governor Actuator Connector	Black
21 Ground & Governor Actuator Connector	Black
22 Ignition Coil (+) Lead, Alt Sense Wire, & # 1 on Gray 12 Pin Connector	Red
23 Ignition Coil (+) Lead, Alt Sense Wire, & # 1 on Gray 12 Pin Connector	Red

Z.E.E.M.S. Side | Machine Side

Back side of Connector
Gray 12 Pin Connector

Connector # What	Wire Color
1 Power to ECU	Red
2 Speed # 1	Red/Black
3 Speed # 2	Yellow/Black
4 Speed # 3	White/Black
5 Fuel Pump	Purple
6 Low Level Driver	White/Green
7 Aux Input Ground	White
8 Starter Solenoid	Green/Black
9 Aux Input 12 Volts	Orange
10 Check Engine Light	Red/White
11 Low Level Lamp Driver	Dark Blue
12 Battery	Red

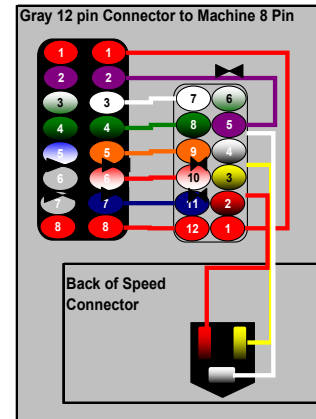

SECTION 4

Z.E.E.M.S. EMISSION CODES

CONDITION	RESULT	TROUBLE CODE	TROUBLE FLAG	CODE/FLAG RETAINED INMEMORY WITH KEY OFF?	EMISSION CONTROL INDICATOR LIGHT
ENGINE OIL PRESSURE SWITCH INDICATES LOW OIL PRESSURE	OIL PRESSURE SWITCH INDICATES OIL PRESSURE IS LOW FOR 1 COMPLETE SECOND - ENGINE SHUTDOWN OCCURS (AFTER 5 SECOND BYPASS DELAY UPON STARTUP)		2	NO	FLASHES CONTINUOUSLY - ALERTS OPERATOR ENGINE SHUTDOWN HAS OCCURRED
ENGINE OVERHEATING DETECTED	COOLANT TEMPERATURE INDICATES OVER HEATING CONDITION (AFTER 40 SECOND HOT SOAK TIME DELAY UPON STARTUP)		3	NO	FLASHES CONTINUOUSLY - ALERTS OPERATOR ENGINE SHUTDOWN HAS OCCURRED
BEGINNING OF DIAGNOSTIC ROUTINE	NO FAULT CONDITION EXISTS - SIGNIFIES BEGINNING OF FLASH CODES	12		YES-ALWAYS PRESENT	ALWAYS FLASHES CODE 12 AT THE BEGINNING OF DIAGNOSTIC CYCLE- SIGNIFIES CIRCUIT IS OPERATIONAL
ENGINE COOLANT SENSOR INDICATES SHORT CIRCUIT OR EXTREME OVERHEATING OF ENGINE (COOLANT TEMP >= 266 F)	TROUBLE CODE IS STORED IN MEMORY	14	3	CODE RETAINED IN MEMORY	UPON INITIAL FAULT- EMISSION CONTROL LIGHT WILL FLASH CONTINUOUSLY ALERTING OPERATOR ENGINE SHUTDOWN HAS OCCURED - UPON RESTART, "EMISSION CONTROL" LAMP IS ON CONTINUOUS INDICATING CODE WAS STORED
ENGINE COOLANT SENSOR INDICATES OPEN CIRCUIT	TROUBLE CODE IS STORED IN MEMORY	15		CODE RETAINED IN MEMORY	ON CONTINUOUS WHILE ENGINE IS RUNNING INDICATING CODE WAS STORED
AIR TEMPERATURE SENSOR INDICATES OPEN CIRCUIT	TROUBLE CODE IS STORED IN MEMORY	23		CODE RETAINED IN MEMORY	ON CONTINUOUS WHILE ENGINE IS RUNNING INDICATING CODE WAS STORED
AIR TEMPERATURE SENSOR INDICATES SHORT CIRCUIT	TROUBLE CODE IS STORED IN MEMORY	24		CODE RETAINED IN MEMORY	ON CONTINUOUS WHILE ENGINE IS RUNNING INDICATING CODE WAS STORED
MAP SENSOR CIRCUIT INDICATES HIGH VLOTAGE (4.98 V OR ABOVE)	TROUBLE CODE IS STORED IN MEMORY	33		CODE RETAINED IN MEMORY	ON CONTINUOUS WHILE ENGINE IS RUNNING INDICATING CODE WAS STORED
MAP SENSOR CIRCUIT INDICATES SHORT TO GROUND	TROUBLE CODE IS STORED IN MEMORY	34		CODE RETAINED IN MEMORY	ON CONTINUOUS WHILE ENGINE IS RUNNING INDICATING CODE WAS STORED
OXYGEN SENSOR - LEAN CONDITION DETECTED	TROUBLE CODE IS STORED IN MEMORY	44		CODE RETAINED IN MEMORY	ON CONTINUOUS WHILE ENGINE IS RUNNING INDICATING CODE WAS STORED
OXYGEN SENSOR - RICH CONDITION DETECTED	TROUBLE CODE IS STORED IN MEMORY	45		CODE RETAINED IN MEMORY	ON CONTINUOUS WHILE ENGINE IS RUNNING INDICATING CODE WAS STORED

Heating System

Note: Make sure the engine and water pump systems are working properly.
NOTE: WATER MAY BE HOT AND UNDER PRESSURE!! EXTREME CAUTION SHOULD BE USED!!

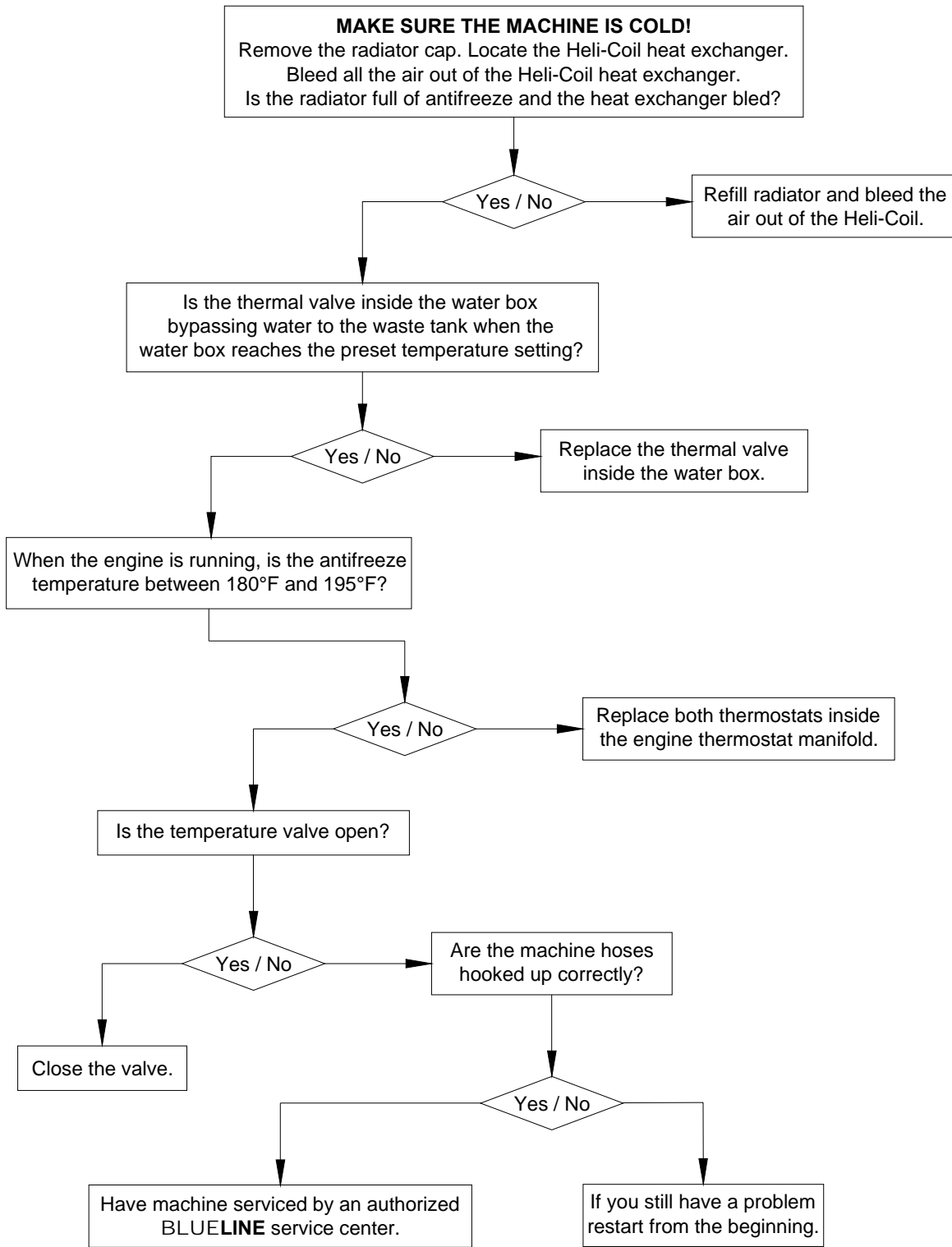

SECTION 5: **PARTS & ACCESSORIES**

9. ILLUSTRATED PARTS LISTINGS

Sheet Metal	48
Engine	52
Water Transfer System	57
Vacuum-Exhaust System	64
Chemical Pumping System	68
Decals	70
Electrical Diagram	72
Optional Equipment	73

10. ACCESSORIES

Accessories	77
-------------	----

SECTION 5

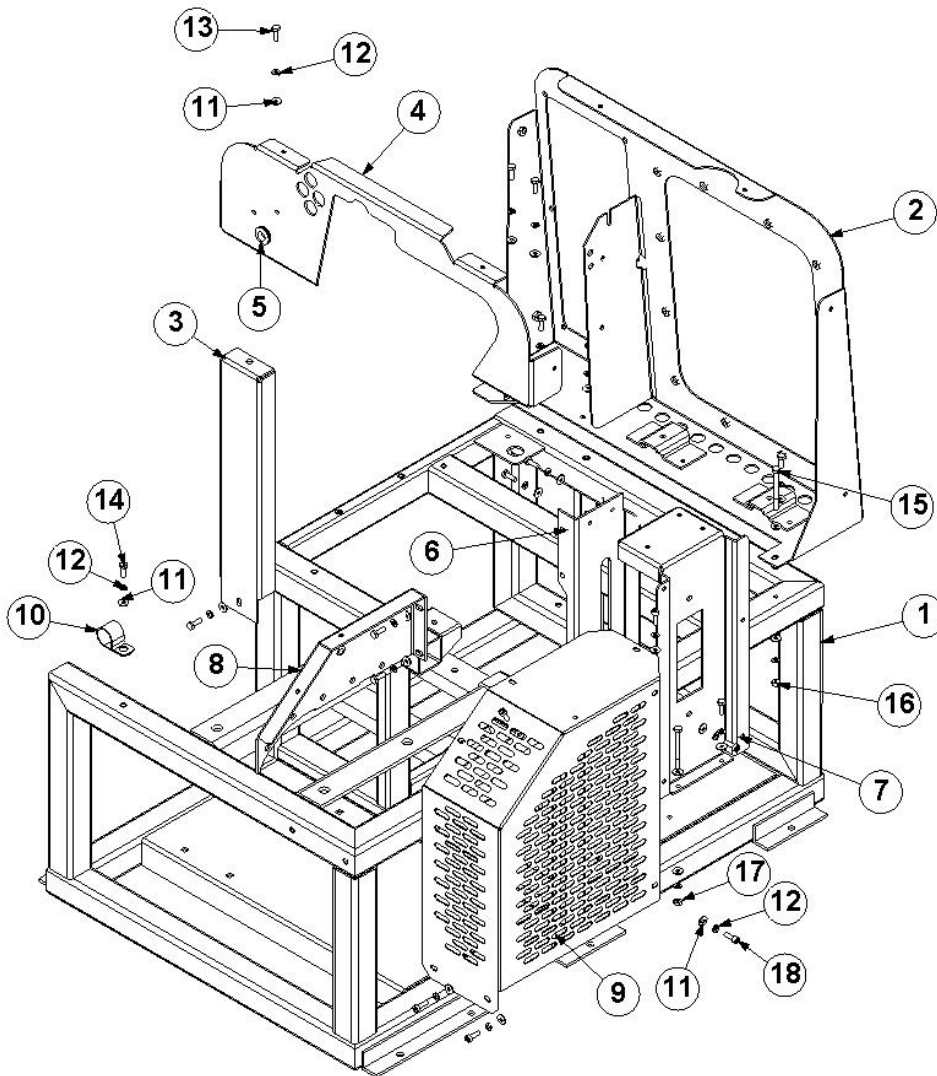

5-1

SHEET METAL FRAME

Item No.	Part Number	Qty	Description
1	61-154	1	ASSY, BASE THERMAL BLUE
2	61-222	1	ASSY, CONTROL PANEL MNT TWII
3	58-080	1	MOUNT, REAR PANEL SUPPORT
4	59-450	1	PNL,UPPER REAR THERMAL WAVE II
5	41-019	1	GROMMET, 1-1/8 OD X 5/8 ID A 5/16
6	59-449	1	PLT,BELT TENSIONER SUPPORT TWII
7	61-165	1	ASSY,TENSIONER BELT THERMALW II
8	61-225	1	ASSY,SUPPORT BELT GUARD TWII
9	61-221	1	ASSY,BLOWER BELT GUARD TWII
10	14-022	1	CLAMP VINYL COVERED COV21092Z1
11	12-011	24	WASHER, FLAT #12 SAE
12	12-015	21	LKWSR, 1/4 ZINC
13	10-020	3	SCREW, MACH 1/4-20 X 3/4 HXHD SS
14	10-032	10	SCREW, MACH 1/4-20 X 3/4 HXHD
15	10-028	3	SCREW, MACH 1/4-20 X 2-3/4 HXHD
16	11-004	1	NUT, 1/4-20 ZINC
17	11-013	1	LKNUT, 1/4-20 NYLOK
18	10-021	6	SCREW, MACH 1/4-20 X 3/4 SOCHD SS

SECTION 5

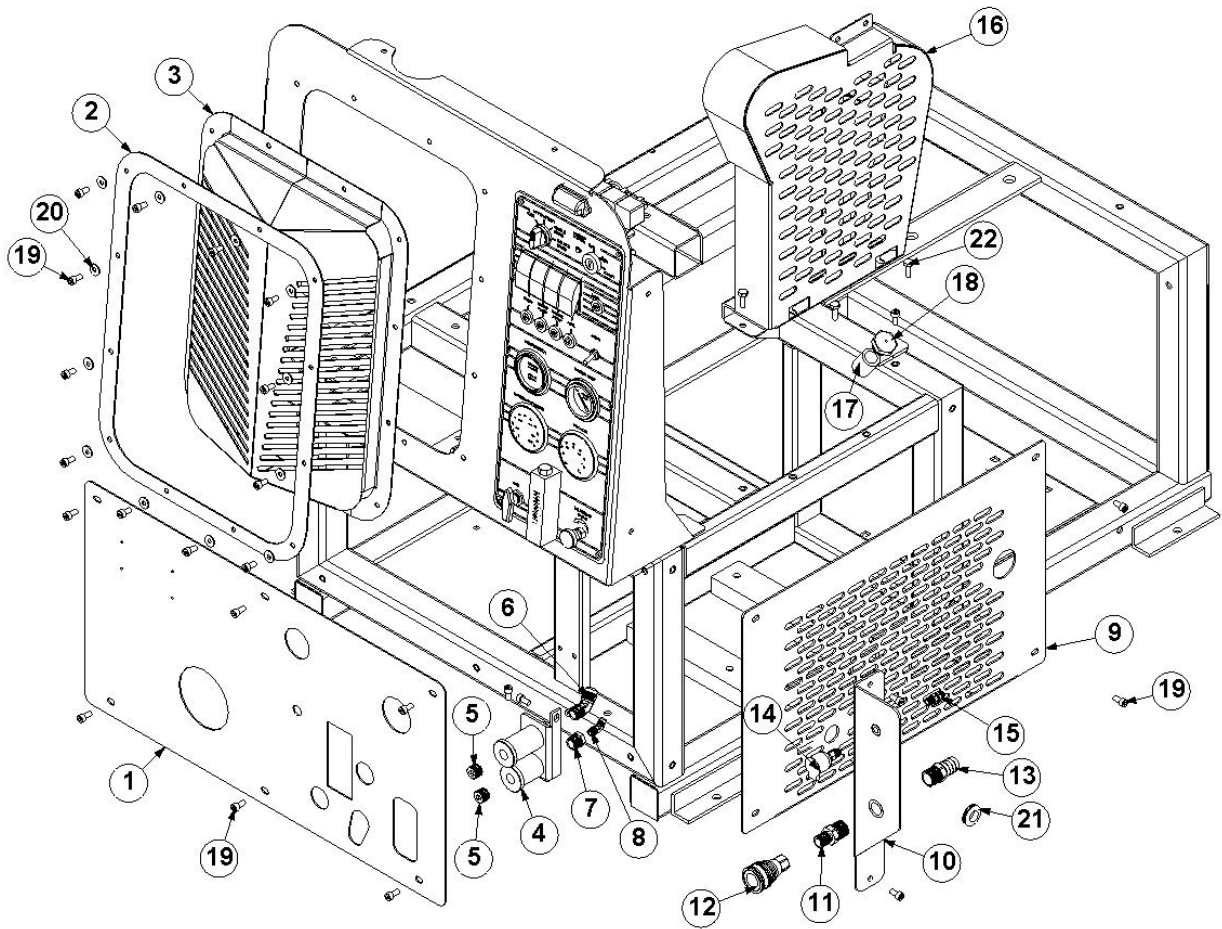

5-2

Front Sheet Metal

Item No.	Part Number	Qty	Description
1	58-172	1	PNL, LOWER FRONT TWII
2	58-092	1	GRILL, RETAINER RING
3	59-304	1	PNL, GRILL MAIN
4	61-146	1	ASSY, BRKT OIL DRAIN
5	21-146	2	PLUG, 3/8 NPT BRASS
6	21-059	1	ELL, 3/8 P X 1/2 T 45DEG BRASS
7	21-088	1	BUSHING, 3/8 X 1/4 BRASS
8	21-051	1	ELL, 1/4 P X 1/4 T 45 DEG BRASS
9	58-082	1	PANEL, LOWER RIGHT
10	61-169	1	ASSY, WATER-OIL CUP CONNECTOR
11	21-030	1	NIP, HEX 1/2 X 3/8 BRASS
12	25-005	1	DSC, 3/8X3/8FP BR
13	21-032	1	FTTG, BARB 1/2 P X 3/4 H BRASS
14	28-000	1	CUP, OILFILL 1/8P
15	21-028	1	CONN, 1/8 P X 1/4 POLY
16	61-205	1	ASSY, GUARD ENGINE TWII
17	61-147	1	ASSY, OIL FILL CAT PUMP
18	36-116	1	CAP, OIL FILL 3CP CAT # 45690
19	10-007	25	SCREW, MACH 1/4-20 X 1/2 SOCHD SS
20	12-011	12	WASHER, FLAT #12 SAE
21	41-019	1	GROMMET, 1-1/8 OD X 5/8 ID A 5/16
22	10-032	3	SCREW, MACH 1/4-20 X 3/4 HXHD

SECTION 5

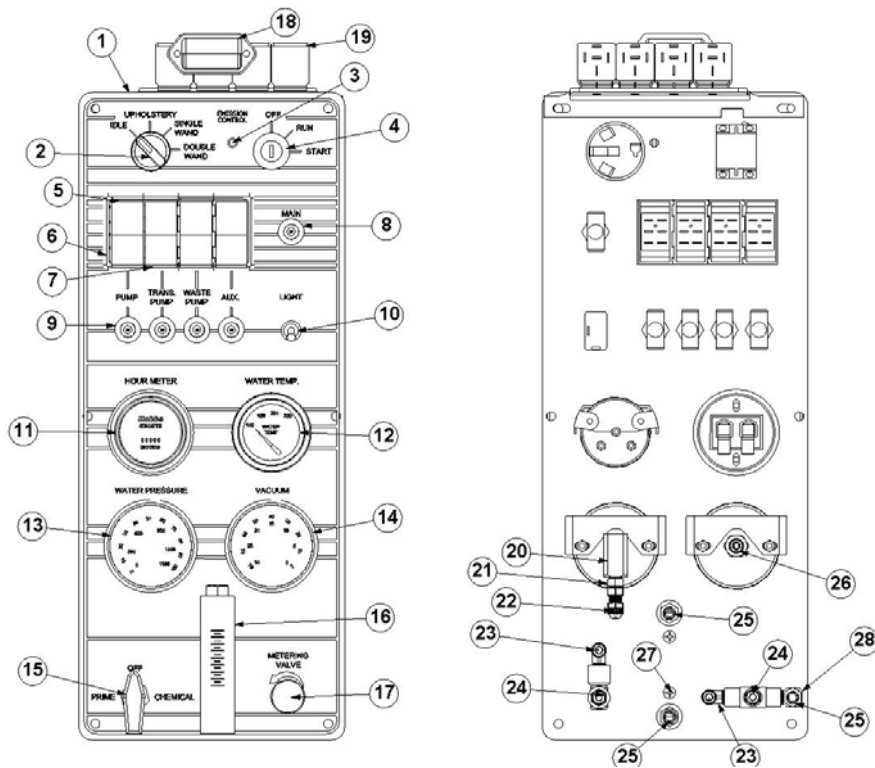

5-3

69-088 ASSY, CONTROL PANEL TW II

Item No.	Part Number	Qty	Description
1	58-131	1	PNL, CONTROL THERMAL II
2	29-011	1	SWITCH, THROTTLE CONTROL
3	30-022	1	LIGHT,LED AMBER
4	29-007	1	SWITCH,STARTER&KEY3POSITION
5	29-012	4	SWITCH, PUMP AND AUX. DSCVRY
6	31-011	2	PANEL, MTG. END # 44383 WAYTEK
7	31-012	2	PANEL, MTG. MIDDLE # 44384 WAYTEK
8	30-007	1	BREAKER, 30 AMP
9	30-008	4	BREAKER, 20 AMP
10	29-001	1	SWITCH, TOGGLE
11	26-010	1	HOURMETER, HOBBS
12	26-007	1	GAUGE,WTR. TEMP 320 DEG
13	26-005	1	GAUGE, WTR. PRESS1500PSIDUAL
14	26-004	1	GUAGE, VAC 30in.HG DUALSCALE
15	23-027	1	VLV, 3-WAY BALL 1/8 FP SS
16	26-003	1	FLOWMETER, 1/8P
17	23-028	1	VLV, MET 1/8FP (CHEM) RT ANG SS
18	30-021	1	LIGHT, UTILITY 12V
19	34-010	4	RELAY, ENG.SHUTDWN12V20/30AMP
20	21-037	1	ELL, 1/4 IN. BRASS
21	21-076	1	BUSHING, 1/4 M X 1/8 F BRASS
22	21-028	1	CONN, 1/8 P X 1/4 POLY
23	21-054	2	ELL, 1-8 P X 1-4 T BRASS
24	21-001	2	CONN, 1/8 P X 1/4 T BR
25	21-007	3	FTTG,BRB 1/8 PX 5/16 H BR
26	21-004	1	CONN, 1/4 F P X 1/4 T BRASS
27	10-033	2	SCREW, MACH 10-32 X 3/8 PHILLIP
28	21-038	1	ELL, STREET 1/8 IN. BRASS

SECTION 5

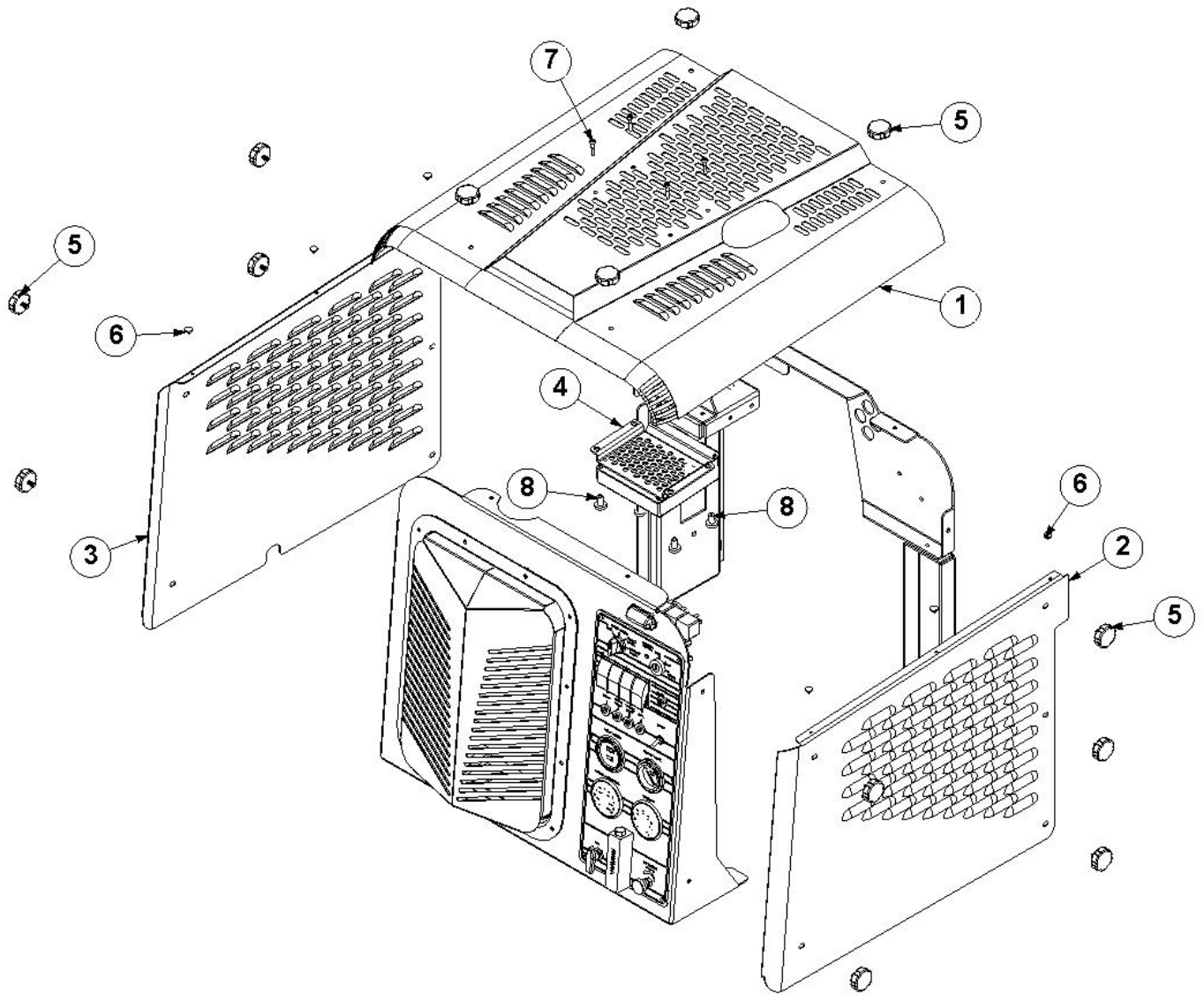

5-4
HOOD ASSEMBLY

Item No.	Part Number	Qty	Description
1	61-196	1	ASSY, HOOD CTR THERMALWAVE II
2	58-089	1	PNL, HOOD RIGHT
3	58-090	1	PNL, HOOD LEFT
4	58-123	1	PNL, MOUNT ZENITH COMPUTER
5	11-007	14	NUT, THUMB 1/4-20 FKWR. HEAD KNOB
6	41-032	6	BUMPER, RUBBER HOOD
7	10-016	4	SCREW, MACHINE 10-32 X 1 SOCHD SS
8	11-002	4	NUT, WELL G 10-32 .375

SECTION 5

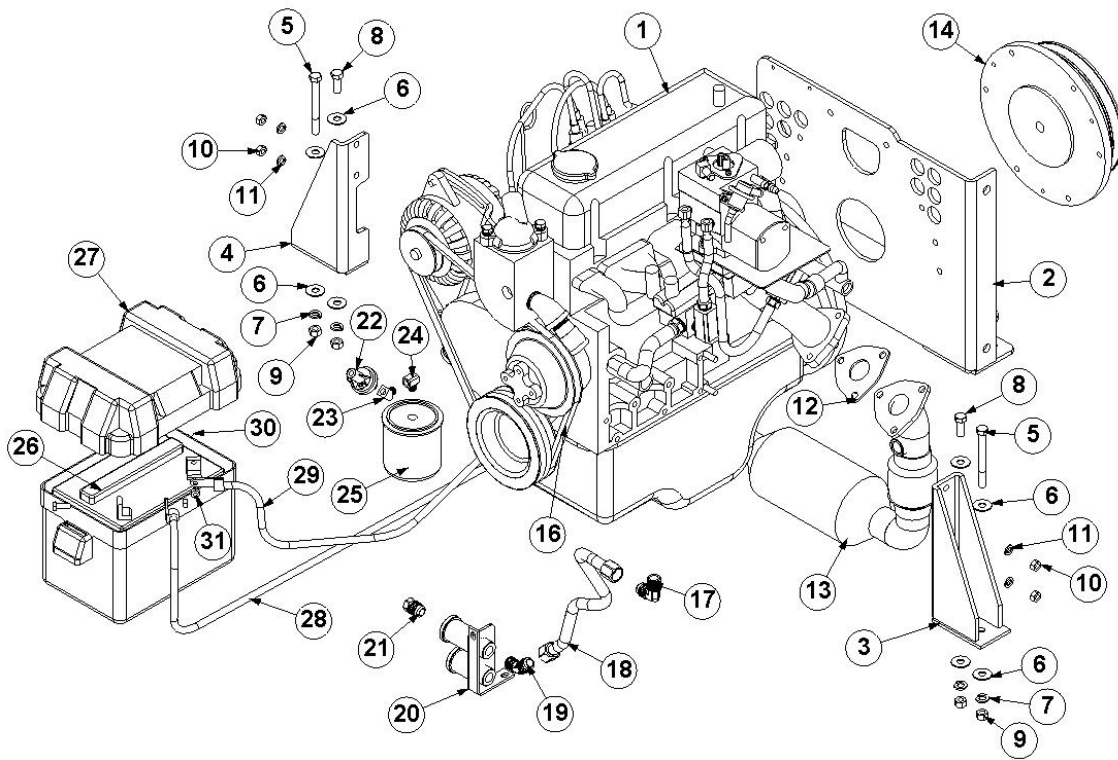

5-5

ENGINE INSTALLATION

Item No.	Part Number	Qty	Description
1	45-007	1	ENGINE, NISSAN A-15 BLUELINE SPC
2	59-434	1	PLT, ENGINE MOUNT THERMAL II
3	61-198	1	ASSY, MOUNT ENGINE RIGHT TWII
4	59-436	1	MT, LEFT CTR ENGINE THERMAL II
5	10-057	2	BOLT, TAP 3/8-16 X 3 GR 5
6	12-017	8	WASHER, FLAT 5/16 SAE
7	12-014	4	LKWSR, 3/8 ZINC
8	10-029	2	SCREW, MACH 3/8-16 X 1 HXHD
9	11-006	4	NUT, 3/8-16 ZINC
10	11-010	4	NUT, M8 HARD
11	12-005	4	LKWSR, M8 HARD
12	36-143	1	GASKET, NISSAN EXHAUST
13	61-197	1	ASSY, CATALYTIC EXHAUST TWII
14	66-009	1	PULLEY, NISSAN A15
15	36-076	1	MODULE, ZEEMS EFI #0-20022
16	37-016	1	BELT, ALT. NISSAN#11720-77702
17	21-016	1	ELL, #6BSTX 1/2 T ZNC PL
18	18-035	1	HOSE, 1/2 X 18 1/2 FT X 1/2 FT W/CVR
19	21-059	1	ELL, 3/8 P X 1/2 T 45DEG BRASS
20	61-146	1	ASSY, BRKT OIL DRAIN
21	21-027	1	PLUG, 1/2 T BRASS
22	29-013	1	SWITCH, OIL PRESSURE HOBBS CLOSED
23	21-099	1	ELL, 1/8 45 DEG BRASS
24	21-038	1	ELL, STREET 1/8 IN. BRASS
25	36-009	1	FILTER, OIL NISSAN A-15
26	35-004	1	BATTERY, 12 VOLT LAWN & GARDEN
27	40-004	1	BOX, BATTERY HOLDER
28	47-002	1	ASSY, BATTERY CABLE BLK THERMAL
29	47-001	1	ASSY, BATTERY CABLE RED THERMAL
30	10-032	2	SCREW, MACH 1/4-20 X 3/4 HXHD
31	11-004	2	NUT, 1/4-20 ZINC

SECTION 5

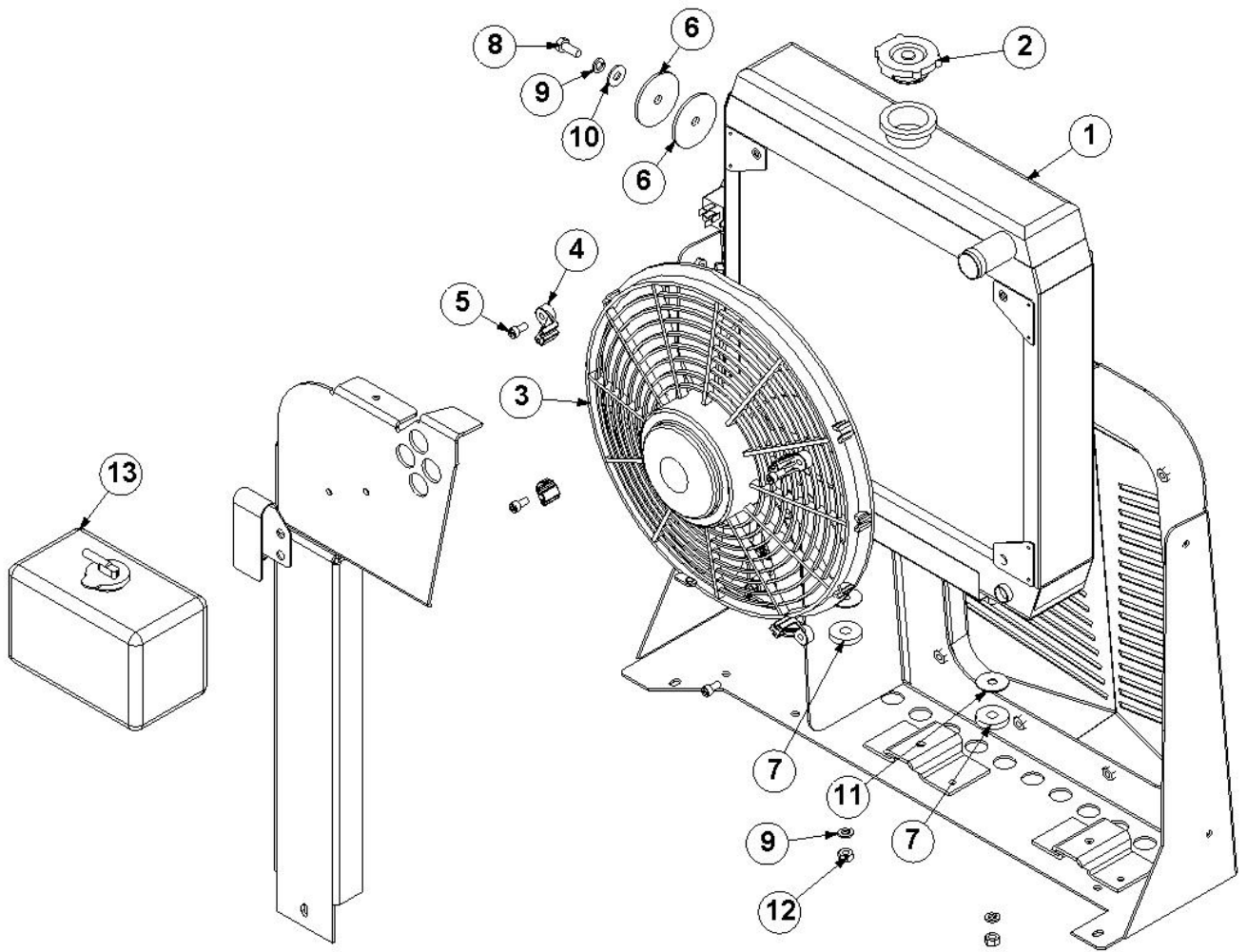

5-6

RADIATOR INSTALLATION

Item No.	Part Number	Qty	Description
1	63-039	1	RADIATOR
2	40-002	1	CAP, RADIATOR A-15
3	35-006	1	FAN, SUMMIT ELECTRIC RADIATOR
4	35-007	4	MOUNT, FEET SPAL ELEC FAN
5	10-007	4	SCREW, MACH 1/4-20 X 1/2 SOCHD SS
6	41-016	2	GROMMET, RAD MTG. SIDE
7	41-013	2	GROMMET, RAD MTG. BTM
8	10-034	1	SCREW, MACH 5/16-18 X 3/4 HXHD
9	12-016	3	LKWSR, 5/16 ZINC
10	12-017	1	WASHER, FLAT 5/16 SAE
11	41-015	2	WASHER, RAD MTG.
12	11-005	2	NUT, 5/16-18 ZINC
13	36-140	1	BOTTLE, O FLOW 2 LITER

SECTION 5

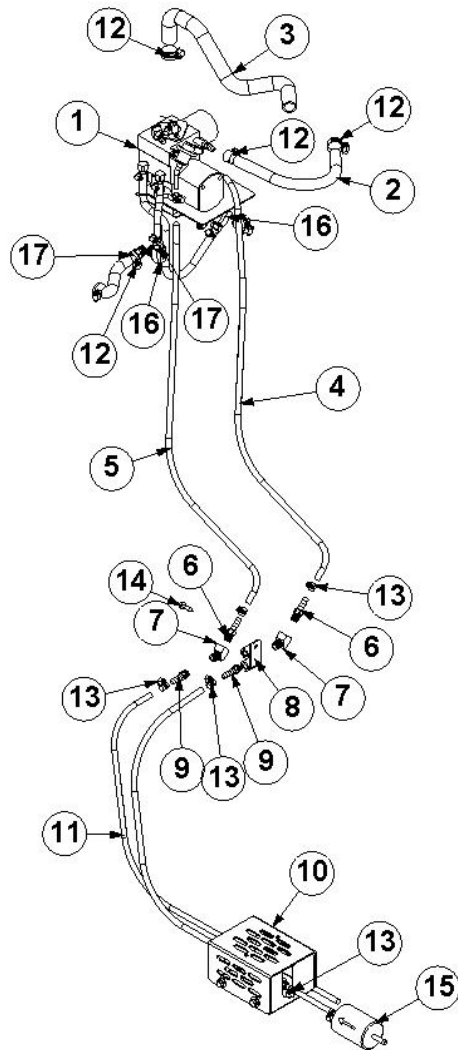

5-7

ENGINE FUEL SYSTEM

Item No.	Part Number	Qty	Description
1	36-076	1	MODULE, ZEEMS EFI #0-20022
2	16-029	1	HOSE, FUEL 3/8 IN 30R7
3	36-117	1	HOSE, PCV THERMAL #249908
4	16-029	1	HOSE, FUEL 3/8 IN 30R7
5	16-029	1	HOSE, FUEL 3/8 IN 30R7
6	21-123	2	FTTG,BRB 1/4 PX 3/8 H BR
7	21-060	2	ELL, STREET 1/4 45DEG BRASS
8	61-204	1	BRKT, FUEL CONNECTOR W/RETURN
9	21-006	2	FTTG, BRB 1/4PX5/16H BR
10	68-087	1	KIT, FUEL HOOK-UP TWII
11	16-029	1	HOSE, FUEL 3/8 IN 30R7
12	14-012	7	CLAMP, HOSE #8
13	14-007	12	CLAMP, HOSE # 4
14	10-035	1	SCREW,1/4 X 1 HXHD
15	36-146	1	FILTER, FUEL ZENITH C282-224
16	21-040	2	ELL, STREET 3/8 IN. BRASS
17	21-081	3	FTTG, BARB 3/8 X 3/8 HOSE
18	16-029	1	HOSE, FUEL 3/8 IN 30R7
19	16-029	1	HOSE, FUEL 3/8 IN 30R7

SECTION 5

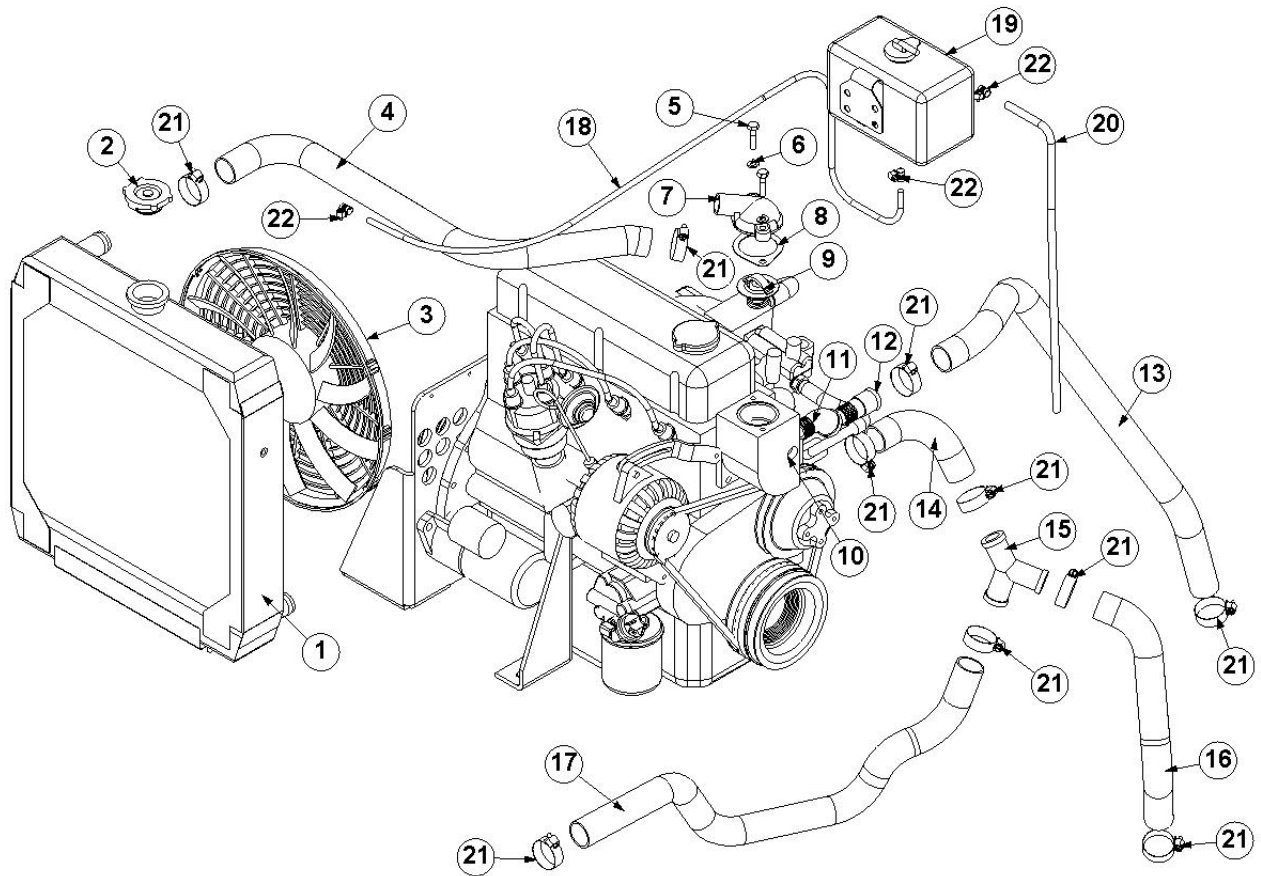

5-8

ENGINE COOLING SYSTEM

Item No.	Part Number	Qty	Description
1	63-039	1	RADIATOR, BLUEWAVE KUBOTA
2	40-002	1	CAP, RADIATOR A-15
3	35-006	1	FAN, SUMMIT ELECTRIC RADIATOR
4	16-008	26"	HOSE, RADIATOR 1-1/8 50 FT BULK
5	10-036	2	SCREW, MACH 5/16-18 X 1-1/4 HXHD
6	12-016	2	LKWSR, 5/16 ZINC
7		1	HOUSING, NISSAN THERMOSTAT
8	36-109	1	GASKET, THERMOSTAT A-15
9	36-127	1	THERMOSTAT, NISSAN A-15 195 DEG
10	66-024	1	MANIFOLD, ENG THERMOSTAT BYPASS
11	21-078	1	ELL, STREET PIPE 3/4 DEG
12	66-033	1	3/4 NPT TO 1-1/8 HOSE
13	16-008	30"	HOSE, RADIATOR 1-1/8 50 FT BULK
14	17-392I	1	HOSE, ENGINE TO Y TWII
15	51-011	1	CASTING, Y COOLANT ADAPTOR
16	16-008	14"	HOSE, RADIATOR 1-1/8 50 FT BULK
17	17-391	1	HOSE, LWR RAD TO Y TWII
18	16-029	36"	HOSE, FUEL 3/8 IN 30R7
19	36-140	1	BOTTLE, O FLOW 2 LITER
20	16-029	30"	HOSE, FUEL 3/8 IN 30R7
21	14-010	10	CLAMP, HOSE #32
22	14-007	3	CLAMP, HOSE #4

SECTION 5

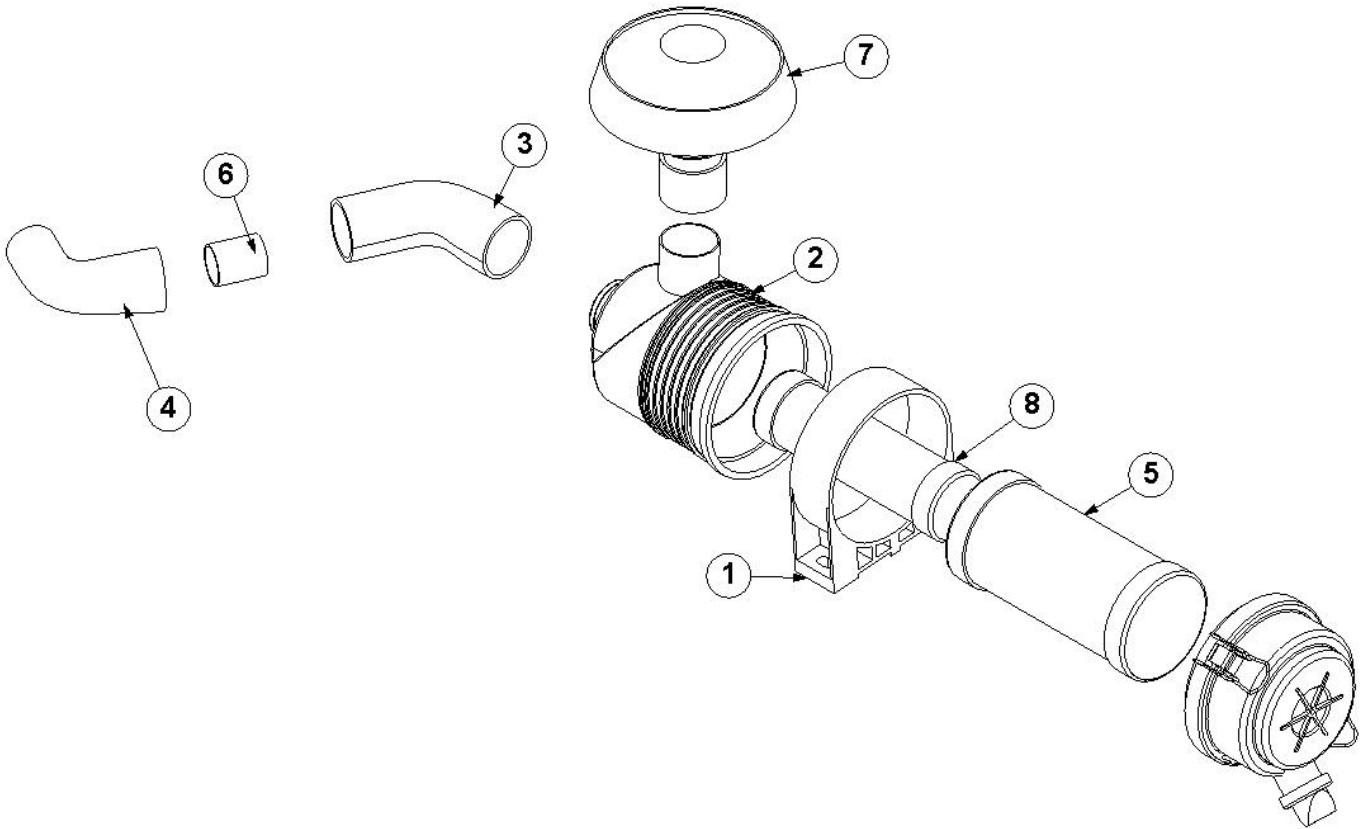

5-9

AIR CLEANER

Item No.	Part Number	Qty	Description
1	36-183	1	BAND, MTG AIR CLEANER DONALDSON
2	36-185	1	ASSY, AIR CLEANER 5.75 IN DNLDSON
3	36-086	1	ELBOW, 2-1/4 X 45 DEG. DONALD.
4	36-085	1	ELBOW, 2-1/4 X 90 DEG. DONALD.
5	36-210	1	FILTER, AIR PRIMARY 5.75 DONALDSON
6	55-025	1	TBG, SS 1-1/4 OD X .049W 304
7	36-186	1	CAP, RAIN 5.75 IN AIR CLEANER
8	36-209	1	FILTER, AIR INTAKE SAFETY

SECTION 5

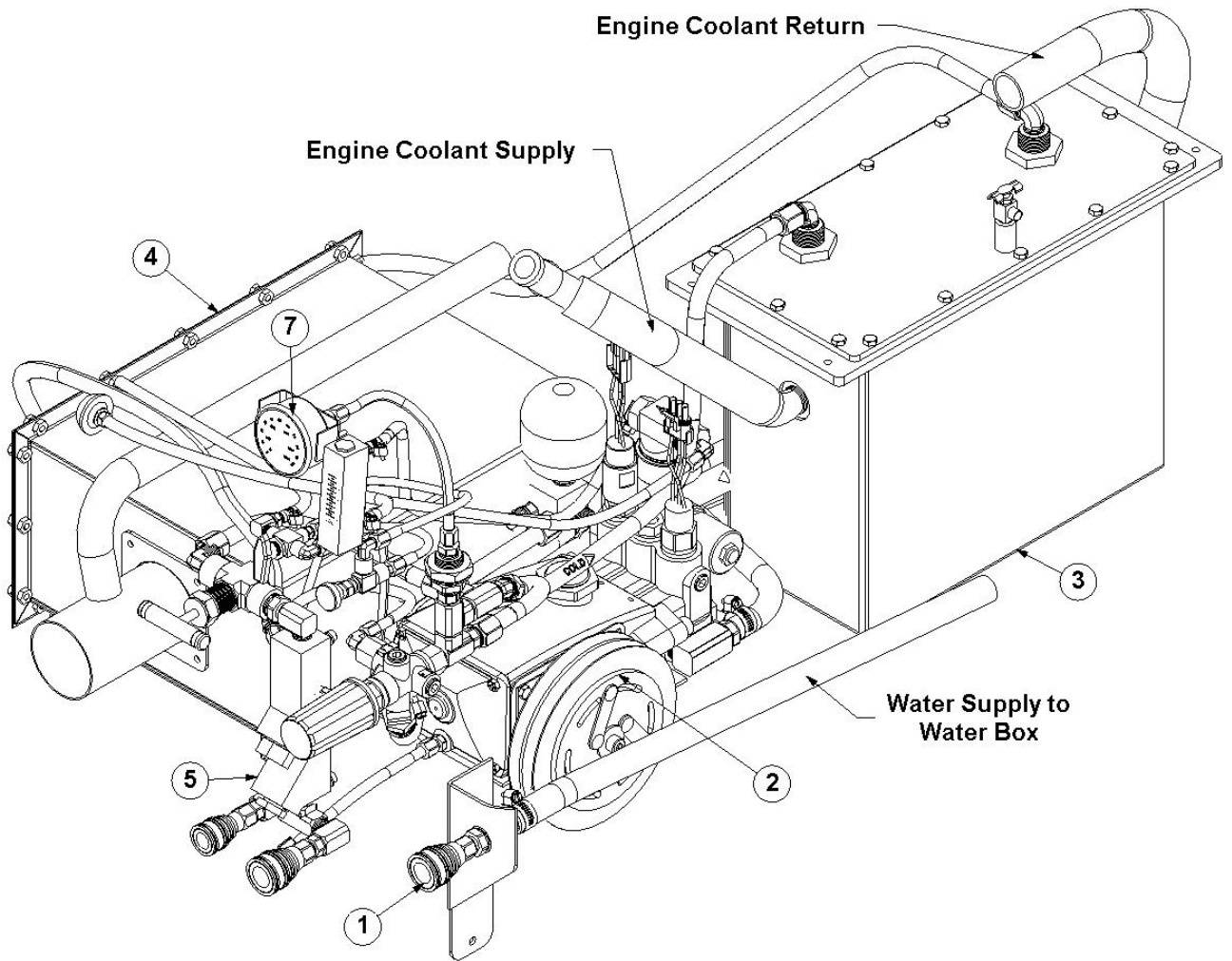

5-10
WATER TRANSFER SYSTEM

Item No.	Part Number	Qty	Description
1	25-005	1	DSC, 3/8X3/8FP BR
2	69-098	1	ASSY, WATER PUMP TWII HP
3		1	Heat Exchanger Assembly1138
4		1	ASSY, HEAT EXCHANGER TW II HP
5	69-095	1	ASSY, Y-STRAINER TWII HP
6	69-096	1	ASSY,PRESS REGULATOR TWII HP
7	26-005	1	GAUGE, WTR. PRESS1500PSIDUAL

SECTION 5

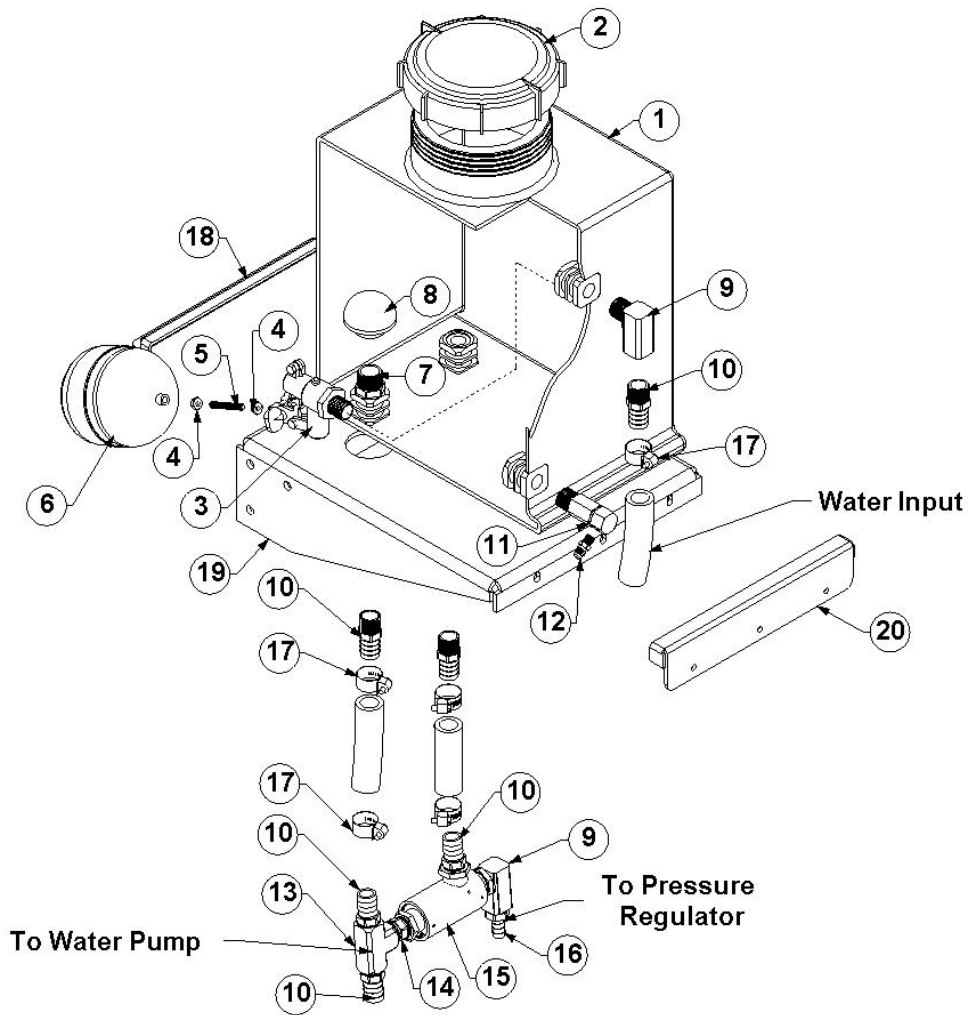

5-11

69-050 ASSY, WATER BOX THERMALWAVE II HP

Item No.	Part Number	Qty	Description
1	51-002	1	MOLDING, WATER BOX DISCOVERY
2	21-025	1	CAP, 5 IN. WATER BOX/TANK BLACK
3	23-025	1	VLV, FLOAT WTR BOX THERMALWAVE
4	11-001	2	NUT, SS 1/4-20
5	64-000	1	ROD, FLOAT SS THERMAL WAVE
6	28-001	1	BALL, FLOAT
7	21-072	1	NIP, HEX 3/4 MP 1/2 MP
8	20-001	1	STRAINER, SUCTION END 3/4FP
9	21-034	2	ELL, STREET 1/2 BRASS
10	21-032	6	FTTG, BARB 1/2 P X 3/4 H BRASS
11	23-033	1	VLV, 165 DEG THERMAL CAT 7145
12	21-001	1	CONN, 1/8 P X 1/4 T BR
13	21-110	1	TEE, 1/2 IN BRASS
14	21-047	1	NIP, 1/2 IN. HEX BRASS
15	23-030	1	VLV, BYPASS 1/2 IN 180 DEG BRASS
16	21-154	1	BARB, 1/2 MP X 1/2 H BRASS
17	14-000	5	CLAMP, HOSE #12
18	58-005	1	BRKT, MTG. WTR BOX HLD DWN LFT
19	59-346	1	MNT, WATER BOX BRKT
20	59-347	1	BRKT, MTG WTRBX HLD DWN RT

SECTION 5

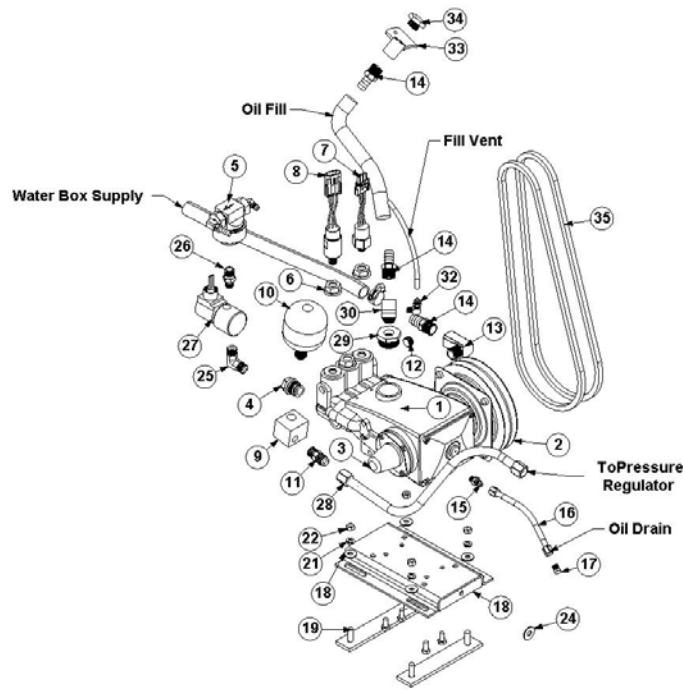

5-12

69-089 ASSY, WATER PUMP TWII

Item No.	Part Number	Qty	Description
1	46-028	1	PUMP, CAT 5CP3120.3 SHAFT
2	35-005	1	CLUTCH, ELECT CAT 5CP 2 GROOVE
3	36-153	1	COVER, SHAFT PROTECTOR
4	66-064	1	ADAPTER,PUMP SS HP
5	46-012	1	PUMP, CHEMICAL STAINLESS STEEL
6	21-038	1	ELL, STREET 1/8 IN. BRASS
7	21-007	1	FTTG,BRB 1/8 PX 5/16 H BR
8	21-066	1	ELL, 1/8 P X 1/4 T SS
9	66-068	2	ADAPTOR, WATER PUMP
10	29-004	1	SWITCH, PRESS (50PSI)
11	29-022	1	SWITCH, PRESS (3000PSI)
12	66-102	1	FTTG, ACCUMULATOR ADAPTOR
13	46-020	1	ACCUMULATOR, CAT 6026
14	21-057	1	CONN, 3/8 P X 1/2 T BRASS
15	21-065	1	PLUG, 1/2 SOLID BRASS HEXHD
16	21-034	1	ELL, STREET 1/2 BRASS
17	21-032	3	FTTG, BARB 1/2 P X 3/4 H BRASS
18	21-050	1	CONN, 1/4 P X 1/4 T BRASS
19	18-062	1	HOSE 3/16 X 10" 1/4FT BS
20	21-048	1	PLUG, 1/8 IN. BRASS
21	61-016	1	MT. PUMP CAT 340 HT
22	61-028	2	PLT, BOLT CAT PUMP
23	12-017	4	WASHER, FLAT 5/16 SAE
24	12-016	4	LKWSR, 5/16 ZINC
25	11-005	4	NUT, 5/16-18 ZINC
26	10-008	4	SCREW, MACH 8MM-16 X 1.25MM
27	12-013	1	WASHER, FLAT 3/8 SAE
28	21-249	1	ELBOW,3/8M X 3/8 M SS
29	21-250	1	NIPPLE,3/8M X 1/4M SS
30	27-023	1	VLV, COIL HP
31	18-054	1	HOSE,1/2X15 1/2FTX1/2FT
32	14-000	1	CLAMP, HOSE #12
33	66-107	1	ADAPTOR, CAT PUMP CAP TWII
34	66-091	1	FTTG,ST ELL 1/2 IN 45 DEG VENT
35	17-060	1	HOSE, WATER 3/4 X 48 IN.

SECTION 5

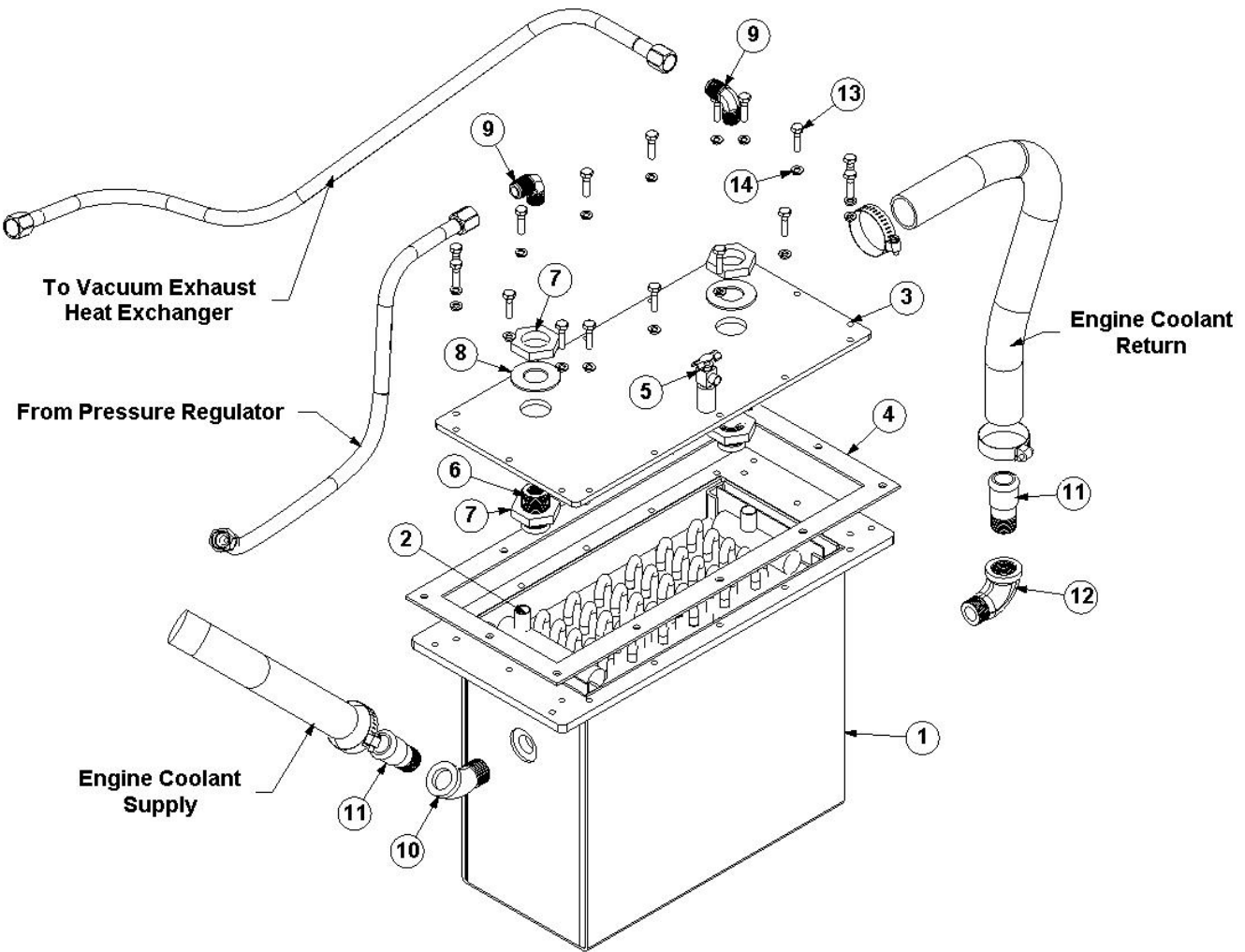

5-13

ENGINE HEAT EXCHANGER

Item No.	Part Number	Qty	Description
1	61-241	1	ASSY,HEAT EXCH ENGINE TWII HP
2	63-062	1	ASSY,VAC HEATER CORE 16 ROW SS
3	61-243	1	ASSY,PNL ENG HEAT EXH CVR
4	41-045	1	GASKET, HEATER BOX HP
5	23-008	1	COCK, DRN 1-4 PX1-4HOS ELL BR
6	66-115	2	FTTG, HELI-COIL STAINLESS ADAPTOR
7	66-116	4	NUT, HELI-COIL STAINLESS
8	41-046	2	WASHER, CUSHION 0.99 ID X 2.0 OD X .093
9	21-015	2	ELL, 1/2 PX 1/2T BR
10	21-078	1	ELL, STREET PIPE 3/4 DEG
11	66-033	2	3/4 NPT TO 1-1/8 HOSE
12	21-077	1	ELL, STREET PIPE 3/4 90 DEG
13	10-026	16	SCREW, MACH 1/4-20 X 1 HXHD
14	12-015	16	LKWSR, 1/4 ZINC

SECTION 5

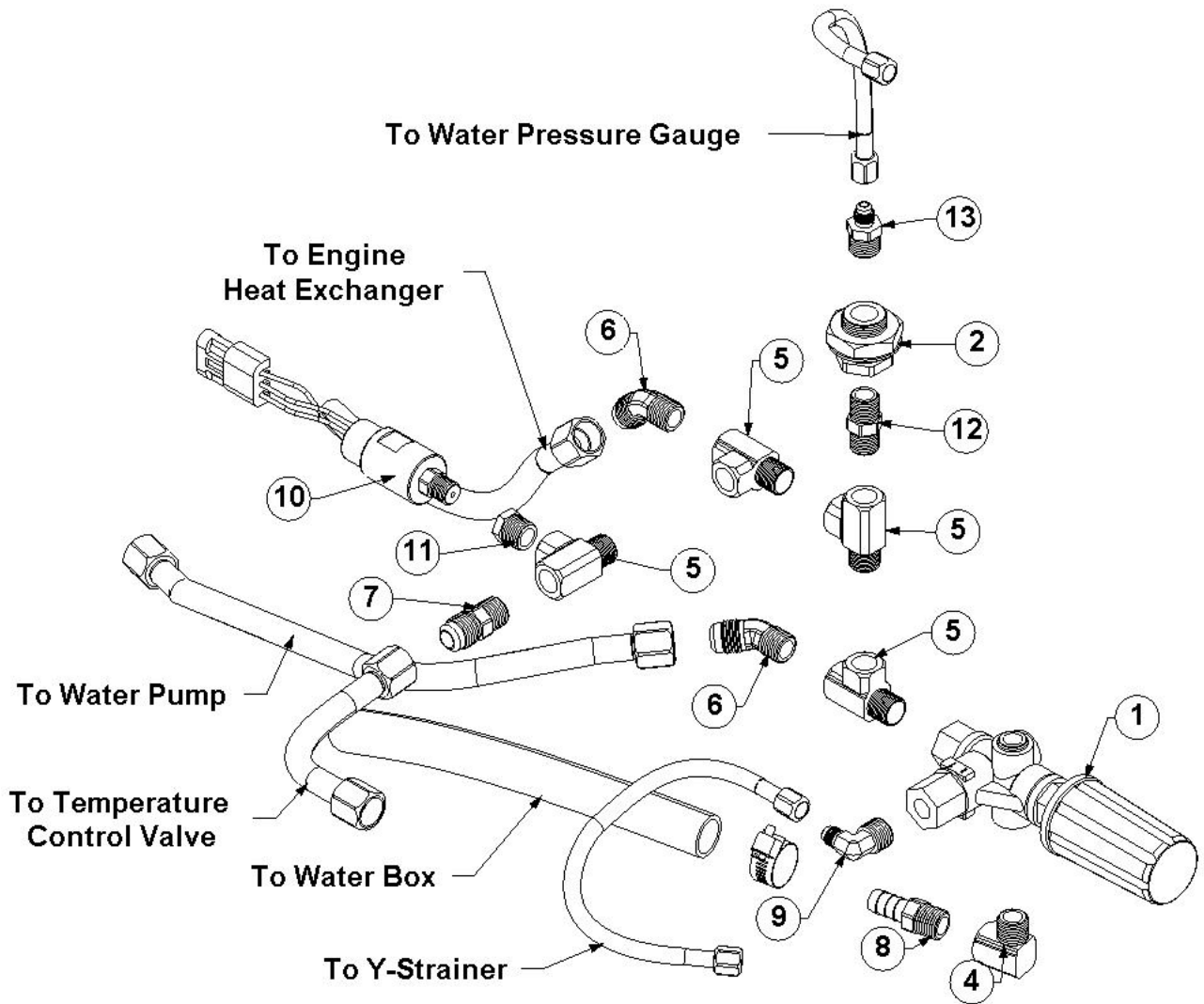

5-14

69-043 ASSY, PRESSURE REGULATOR

Item No.	Part Number	Qty	Description
1	23-039	1	REG, PRESSURE 7690 VITON
2	21-080	1	FTTG, BULHEAD 3/8 BRASS
3	21-146	2	PLUG, 3/8 NPT BRASS
4	21-040	1	ELL, STREET 3/8 IN. BRASS
5	21-062	4	TEE, 3/8 F X M X F BRASS
6	21-059	2	ELL, 3/8 P X 1/2 T 45DEG BRASS
7	21-057	1	CONN, 3/8 P X 1/2 T BRASS
8	21-014	1	FTTG, BRB 3/8 PX 1/2 H BR
9	21-063	1	ELL, 3/8 P X 1/4 T BRASS
10	29-005	1	SWITCH, PRESS (1000PSI)
11	21-088	1	BUSHING, 3/8 X 1/4 BRASS
12	21-046	1	NIP, 3/8 IN. HEX BRASS
13	21-017	1	CONN, 3/8 P X 1/4 T BR

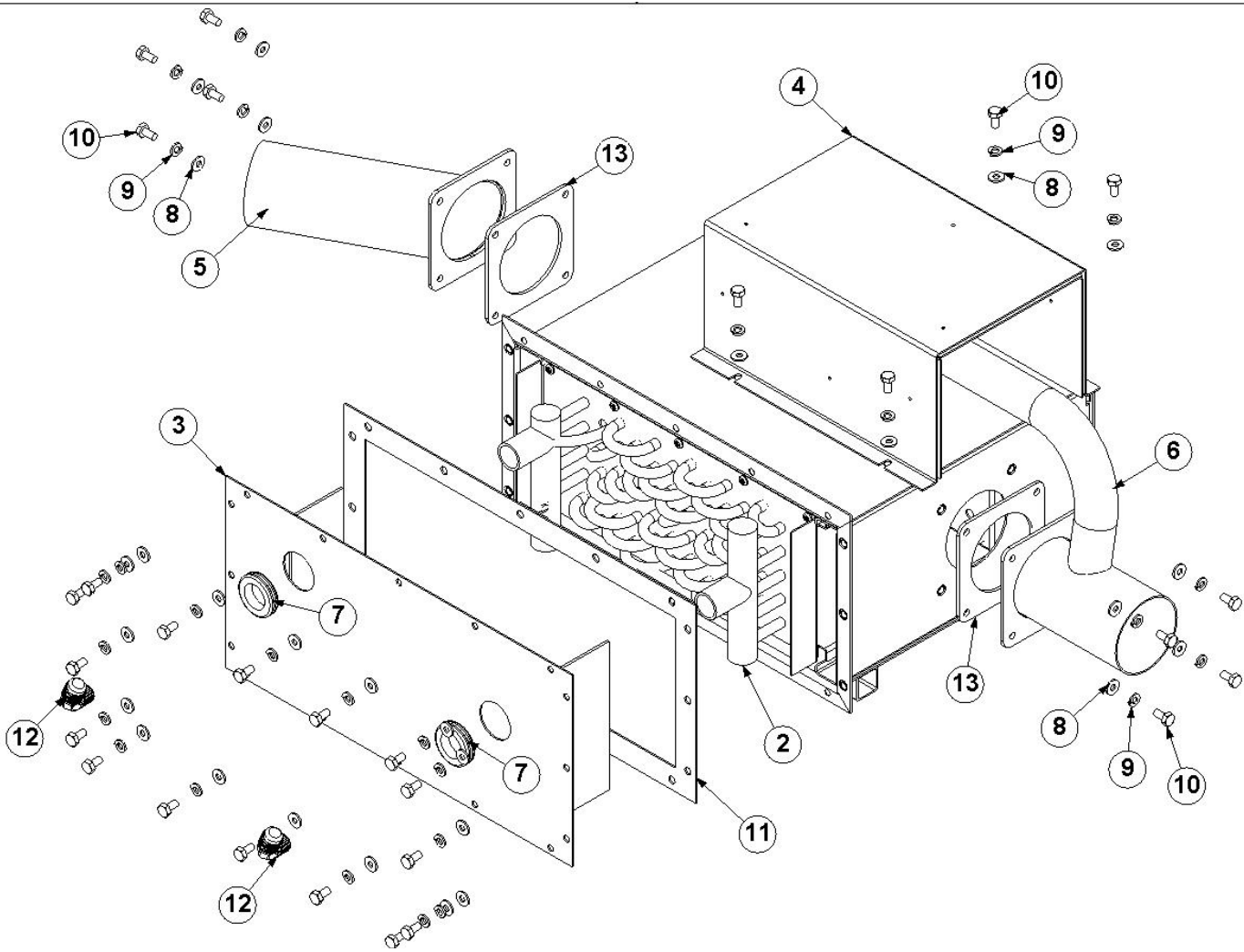

5-16

69-090 ASSY, HEAT EXCHANGER TWII

Item No.	Part Number	Qty	Description
1	61-220	1	ASSY, HEAT EXCHANGER TWII
2	63-061	1	ASSY,ENG HEATER CORE 12 ROW SS
3	61-126	1	ASSY, HEAT EXCHANGER COVER
4	68-074	1	ASSY, EXHST HEAT SHIELD TWII
5	61-194	1	ASSY, VAC EXHAUST TUBE TWII
6	61-202	1	ASSY, EXHAUST THERMALWAVE II
7	41-033	2	GROMMET, 1 ID X 1-3/4OD
8	12-011	28	WASHER, FLAT #12 SAE
9	12-015	28	LKWSR, 1/4 ZINC
10	10-006	28	SCREW, MACH 1/4-20 X 1/2 HEXHD
11	41-029	1	GASKET, HEATER CORE
12	21-061	2	ELL, 3/8 P X 1/2 T BRASS
13	41-037	2	GASKET, HIGH TEMP SILENCER EXHST

SECTION 5

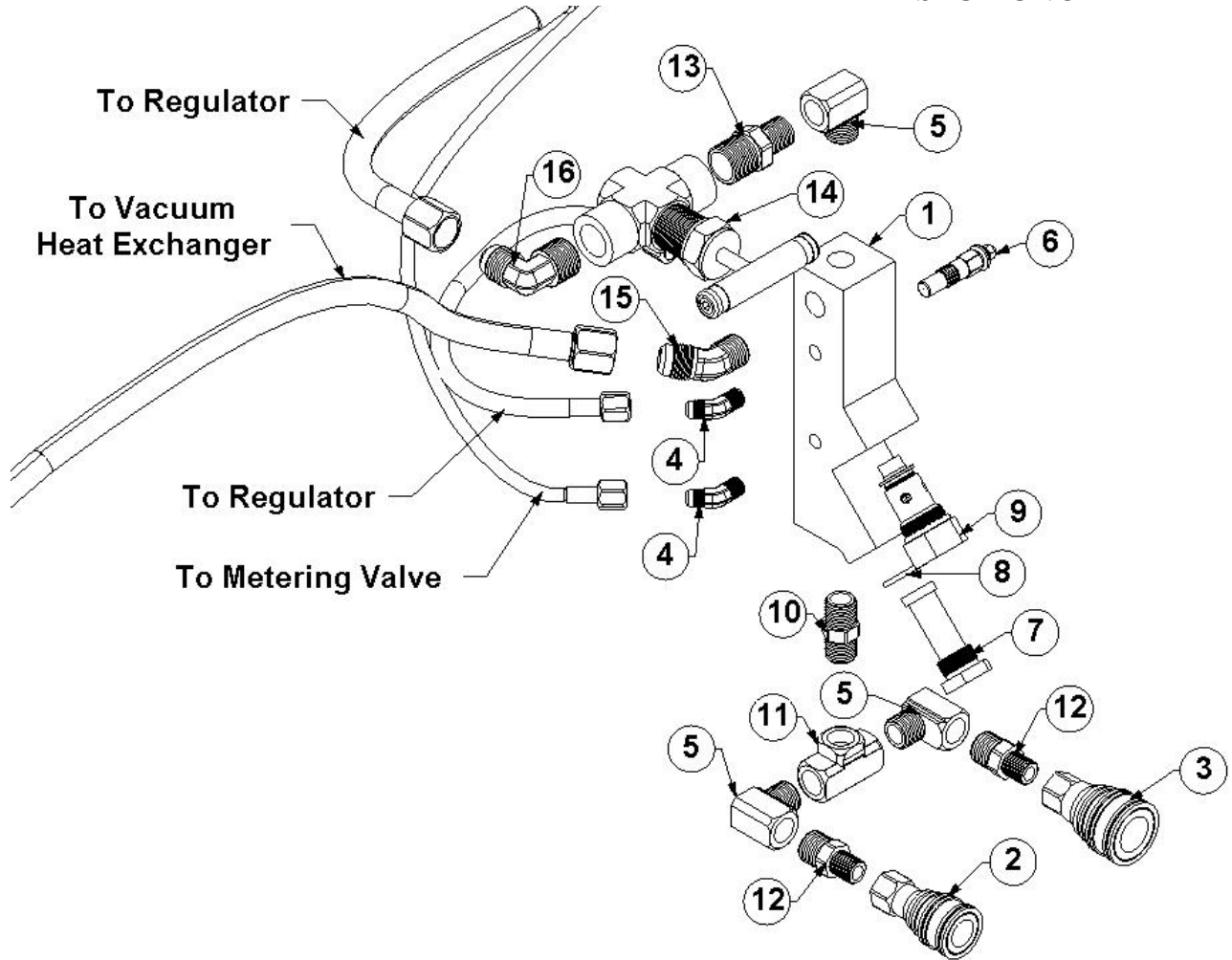

5-18

ASSY, Y-STRAINER

Item No.	Part Number	Qty	Description
1	66-075	1	MANIFOLD, CHECK VALVE BW (YSTRAIN)
2	25-001	1	DSC, 1/4X1/4FP BR
3	25-012	1	DSC, 3/8FX3/8FP SS
4	21-055	2	ELL, 1/8 P X 1/4 T 45DEG BRASS
5	21-040	3	ELL, STREET 3/8 IN. BRASS
6	34-000	1	SENDER, TEMP 140-320 DEGREE
7	20-018	1	SCREEN, CHECK VALVE MANIFOLD
8	41-007	1	ORING, 7/8 ID 1-1/16 OD
9	23-023	1	VLV, CHECK, CHECK VLV MANIFOLD
10	21-046	1	NIP, 3/8 IN. HEX BRASS
11	21-041	1	TEE, 3/8 IN. BRASS
12	21-052	2	NIP, 3/8 X 1/4 HEX BRASS
13	21-030	1	NIP, HEX 1/2 X 3/8 BRASS
14	23-044	1	VLV, CONTROL BLUEWAVE
15	21-059	1	ELL, 3/8 P X 1/2 T 45DEG BRASS
16	21-015	1	ELL, 1/2 P X 1/2 T BRASS

SECTION 5

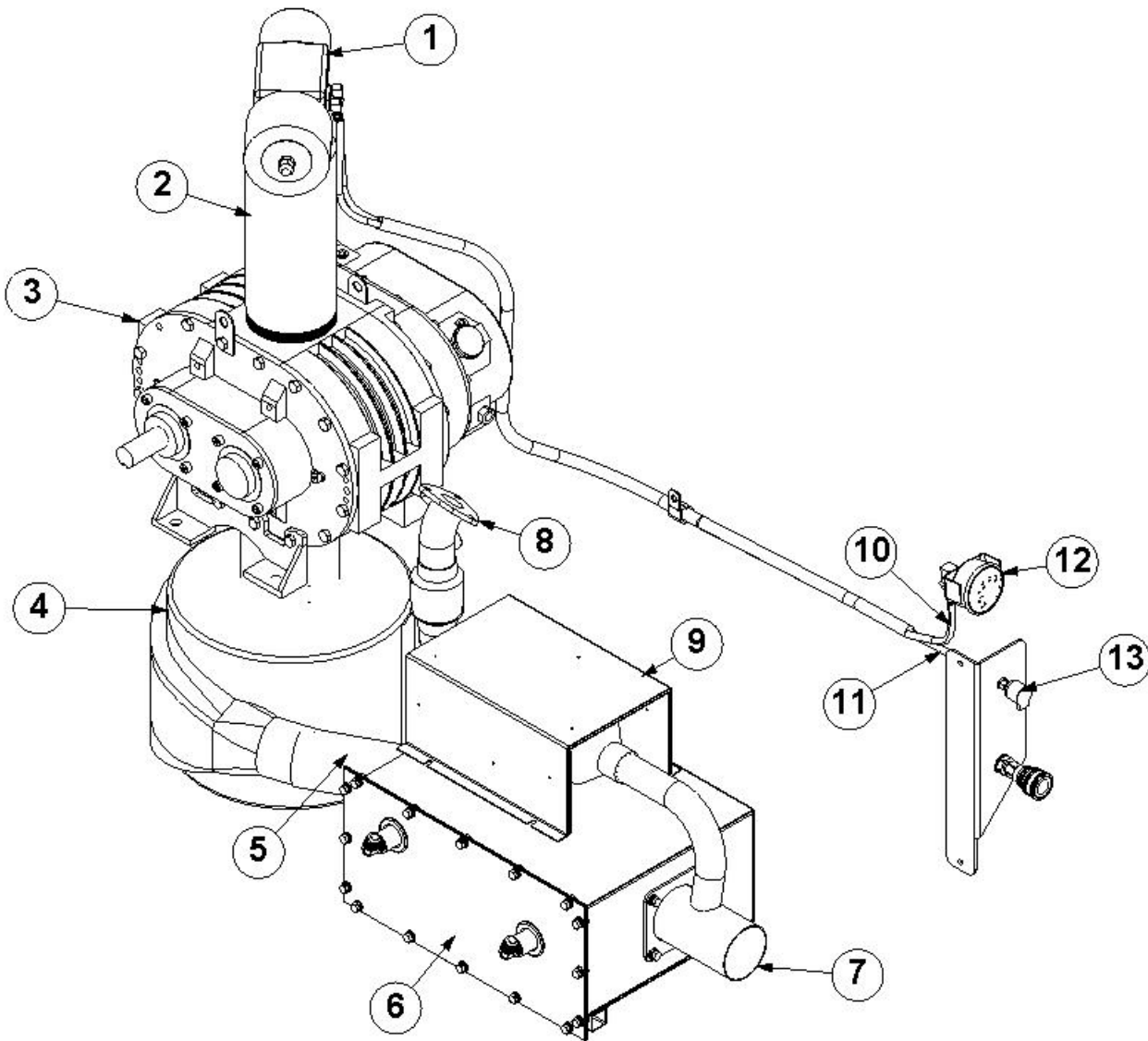

5-20

VACUUM-EXHAUST SYSTEM

Item No.	Part Number	Qty	Description
1	69-040	1	ASSY,VAC BRAKE 5M
2	61-034*	1	ASSY, ADAPTOR VAC STANDPIPE
3	46-013	1	VACUUM PUMP 5M
4	63-055	1	MUFFLER, VACUUM 5M
5	61-194	1	ASSY, VAC EXHAUST TUBE TWII
6	69-090	1	ASSY, HEAT EXCHANGER TWII
7	61-202	1	ASSY, EXHAUST THERMALWAVE II
8	61-197	1	ASSY,CATALYTIC EXHAUST TWII
9	68-074	1	ASSY, EXHST HEAT SHIELD TWII
10	16-017	1	TUBING, IMPOLENE 250FT.
11	16-017	1	TUBING, IMPOLENE 250FT.
12	26-004	1	GUAGE, VAC 30in.HG DUALSCALE
13	28-000	1	CUP, OILFILL 1/8P

*61-195 with sub-mount water tank

SECTION 5

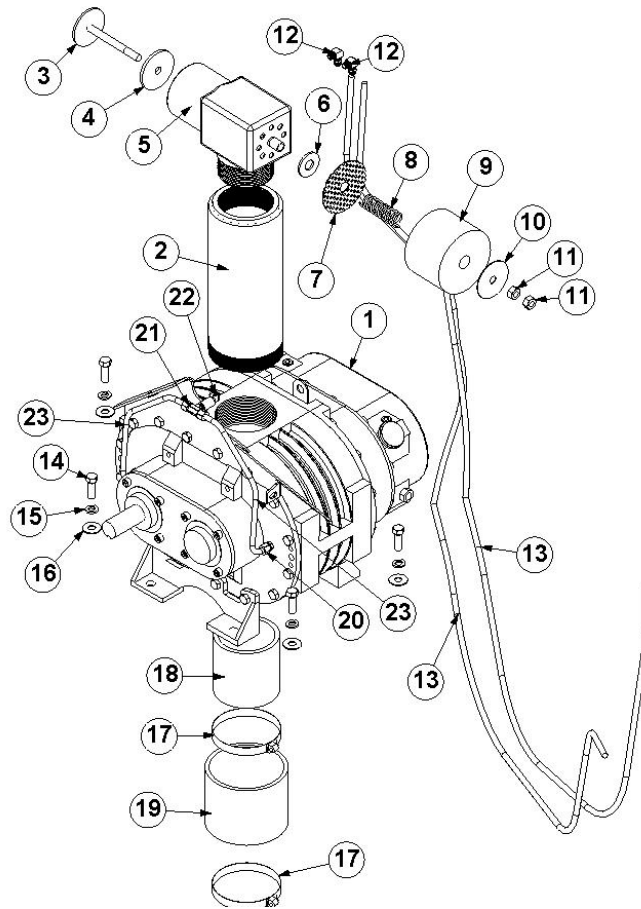

5-21

VACUUM PUMP ASSY

Item No.	Part Number	Qty	Description
1	46-013	1	VACUUM PUMP 5M
2	61-034*	1	ASSY, ADAPTOR VAC STANDPIPE
3	61-035	1	STEM, VACUUM RELIEF VLV 4L,5M
4	41-009	1	DIAPHRAGM, VAC RELIEF VLV 4L, 5M
5	66-001	1	VAC BRAKE, MACHINED 4L
6	58-106	1	SPACER, .125 X .688 X 1.625
7	58-108	1	SCREEN, SILENCER THERMAL
8	15-002	1	SPRING, VAC RELIEF VALVE
9	50-000	1	SILENCER, VAC BRAKE FOAM
10	58-077	1	WASHER,VAC SILENCER
11	11-012	2	NUT, 7/16-14 ZINC
12	21-011	2	ELL, 1/8 P X 1/4 POLY BR
13	16-017	2	TUBING, IMPOLENE 250FT.
14	10-041	4	SCREW, MACH 7/16-14 X 1-1/4 HXHD
15	12-020	4	LKWSR, 7/16 ZINC
16	12-021	4	WASHER, FLAT 7/16 ZINC
17	14-026	2	CLAMP,HOSE #80
18	64-002	1	NIP, HALF BLOWER OUTLET
19	17-706	1	HOSE, INT VACUUM 4-1/2 X 4 IN.
20	21-167	2	FTTG,1/8P X 5/16 TUBE STRAIGHT
21	21-168	1	FTTG,1/8P X 5/16 TUBE TEE
22	28-003	1	FITTING, GREASE 1/8" 90 DEG
23	55-052	2	TBG, 5/16 X 10FT COPPER

*61-195 with sub-mount water tank

SECTION 5

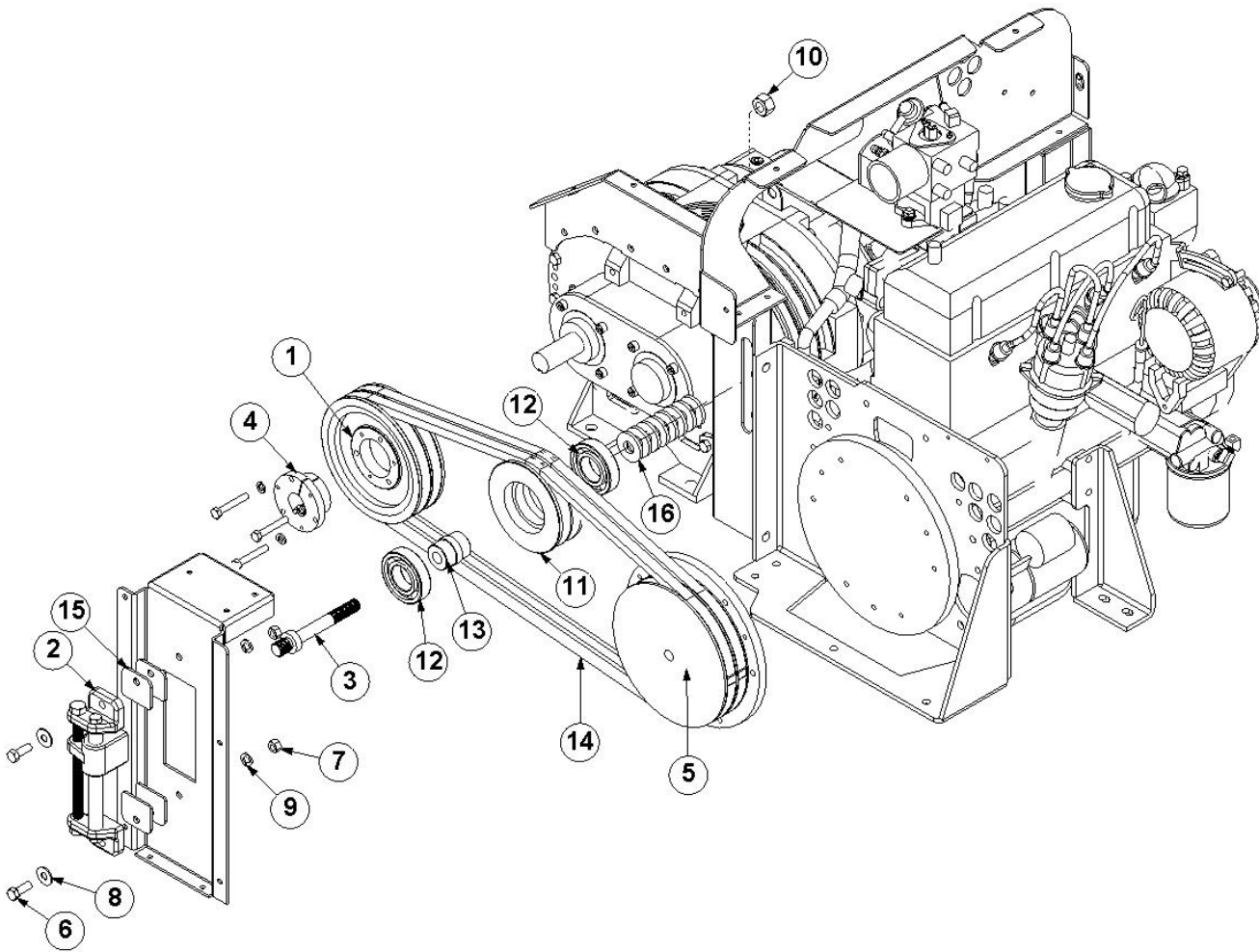

5-22

IDLER PULLEY ASSEMBLY

Item No.	Part Number	Qty	Description
1	38-013	1	PULLEY, 2B66
2	38-017	1	TENSIONER, RIGID
3	66-051	1	IDLER BELT TENSIONER
4	38-014	1	HUB, SDS102
5	66-009	1	PULLEY, NISSAN A15
6	10-029	2	SCREW, MACH 3/8-16 X 1 HXHD
7	11-006	2	NUT, 3/8-16 ZINC
8	12-013	2	WASHER, FLAT 3/8 SAE
9	12-014	2	LKWSR, 3/8 ZINC
10	11-016	1	NUT, HEX 5/8-11
11	66-067	1	PULLEY, TENSIONER 4.40 2G
12	39-018	2	BEARING, 35MM X 72MM X 17MM
13	66-080	1	SHAFT, TENSIONER 4.4 PULLEY
14	37-044	2	BELT, 5VX660
15	58-167	4	PNL, SPACER BELT TENSIONER TWII
16	58-107	8	SPACER, .190 X .688 X 1.625

SECTION 5

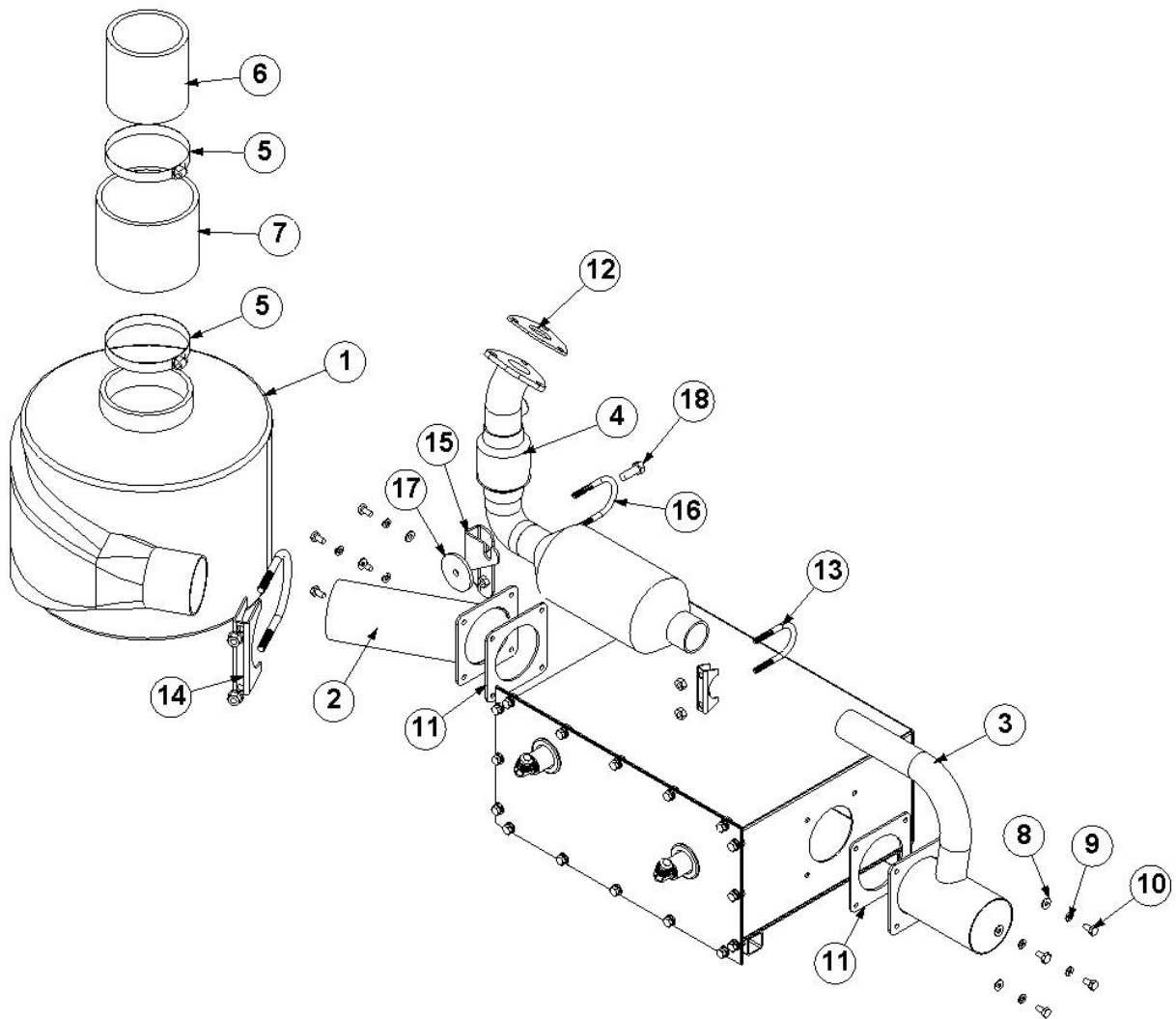

5-24

MUFFLER-EXHAUST ASSEMBLY

Item No.	Part Number	Qty	Description
1	63-055	1	MUFFLER, VACUUM 5M REV
2	61-194	1	ASSY, VAC EXHAUST TUBE TWII
3	61-202	1	ASSY, EXHAUST THERMALWAVE II
4	61-197	1	ASSY,CATALYTIC EXHAUST TWII
5	14-026	2	CLAMP,HOSE #80
6	64-002	1	NIP, HALF BLOWER OUTLET
7	17-706	1	HOSE, INT VACUUM 4-1/2 X 4 IN.
8	12-011	8	WASHER, FLAT #12 SAE
9	12-015	8	LKWSR, 1/4 ZINC
10	10-006	8	SCREW, MACH 1/4-20 X 1/2 HEXHD
11	41-037	2	GASKET, HIGH TEMP SILENCER EXHST
12	36-143	1	GASKET, NISSAN EXHAUST
13	14-001	1	CLAMP, MUFFLER 1-1/4 IN.
14	14-002	1	CLAMP, MUFFLER 3 IN.
15	58-087	1	BRKT, CATALYST MOUNT TM
16	14-027	1	CLAMP, MUFFLER 1-1/2 IN.
17	41-010	1	DIAPHRAGM, VAC RELIEF VLV 3L, 4M
18	10-029	1	SCREW, MACH 3/8-16 X 1 HXHD

SECTION 5

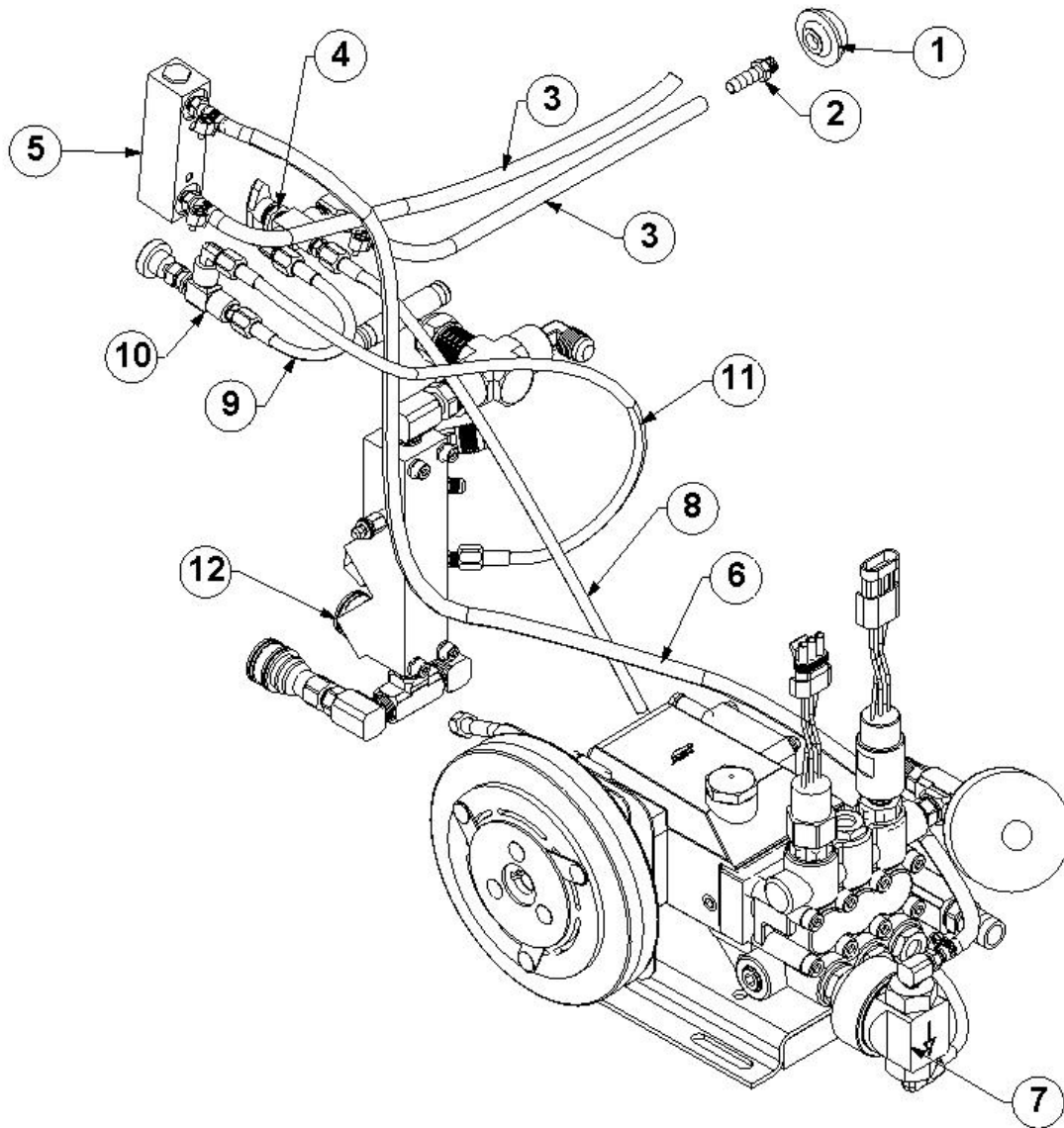

5-25

CHEMICAL PUMPING SYSTEM

Item No.	Part Number	Qty	Description
1	20-002	1	STRAINER, SUCTION END 1/8FP
2	21-007	1	FTTG,BRB 1/8 PX 5/16 H BR
3	17-309	2	HOSE, BRAIDED 5/16 X 65IN.
4	23-027	1	VLV, 3-WAY BALL 1/8 FP SS
5	26-003	1	FLOWMETER, 1/8FP
6	17-311	1	HOSE, BRAIDED 5/16 X 35IN.
7	46-012	1	PUMP, CHEMICAL STAINLESS STEEL
8	18-091	1	HOSE, 3/16 X 35 1/4FT X 1/4FT
9	18-029	1	HOSE, 3/16 X 11-3/4 1/4FT X 1/4FT
10	23-028	1	VLV, MET 1/8FP (CHEM) RT ANG SS
11	18-061	1	HOSE 3/16 X 22" 1/4FT
12	69-038	1	ASSY, Y-STRAINER

SECTION 5

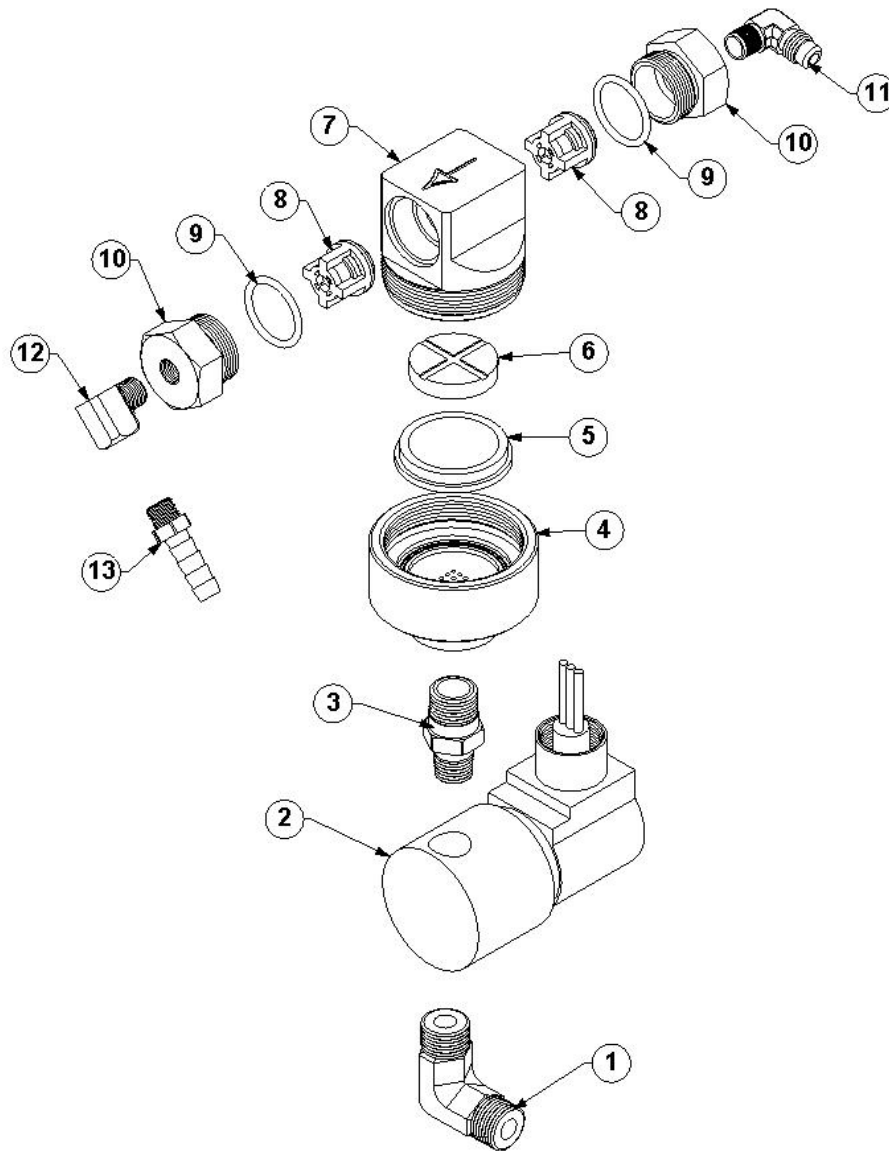

5-26

STAINLESS STEEL CHEMICAL PUMP

Item No.	Part Number	Qty	Description
1	66-008	1	BODY, CHEMICAL PUMP STAINLESS
2	36-004	2	VLV, CHECK HYPRO
3	41-007	2	ORING, 7/8 ID 1-1/16 OD
4	66-006	2	CAP, CHECK VALVE CHEM PUMP SS
5	36-003	1	DISC, CHEM PUMP
6	36-000	1	DIAPHRAGM, CHEMICAL PUMP
7	66-007	1	COVER, CHEMICAL PUMP STAINLESS
8	21-038	1	ELL, STREET 1/8 IN. BRASS
9	21-007	1	FTTG,BRB 1/8 PX 5/16 H BR
10	14-011	1	CLAMP, HOSE FUEL #6
11	21-066	1	ELL, 1/8 P X 1/4 T SS
12	66-002	1	ADAPTOR, CHEMICAL PUMP
13	17-311	1	HOSE, BRAIDED 5/16 X 35IN.

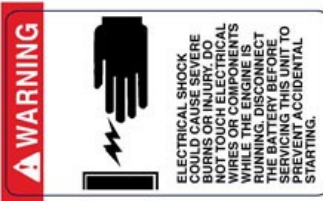

- EXHAUST
- VACUUM INLETS
- WATER INLET
- ENGINE OIL DRAIN
- SOLUTION OUTLETS
- SOLUTION OUTLET
- WASTE OUTLET
- PRESSURE REGULATOR
- VACUUM LUBRICATION
LUBRICATE WITH VACUUM INLETS SEALED

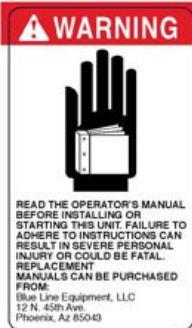
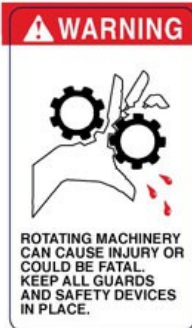

44-000 DECAL SHEET, WARNING & CONTROLS

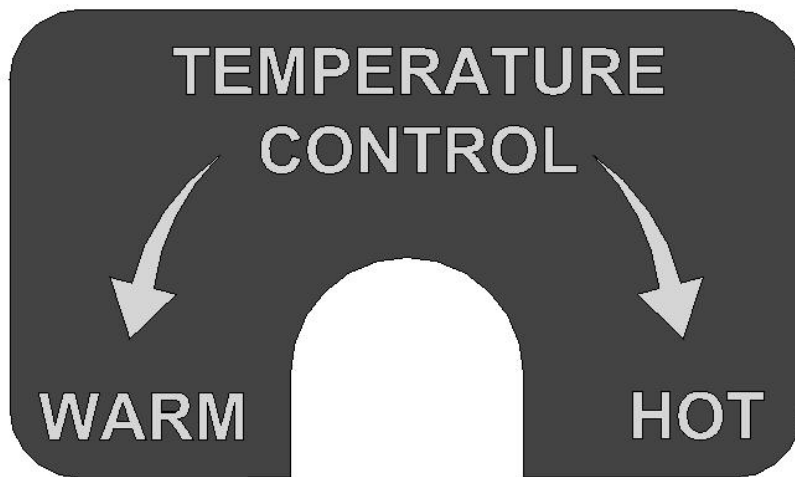

44-024 DECAL, TEMPURATURE CONTROL



44-001 DECAL, HOOD BLUELINE



44-031 DECAL, GRILL THERMALWAVE II

5-27

SECTION 5

ELECTRICAL DIAGRAM

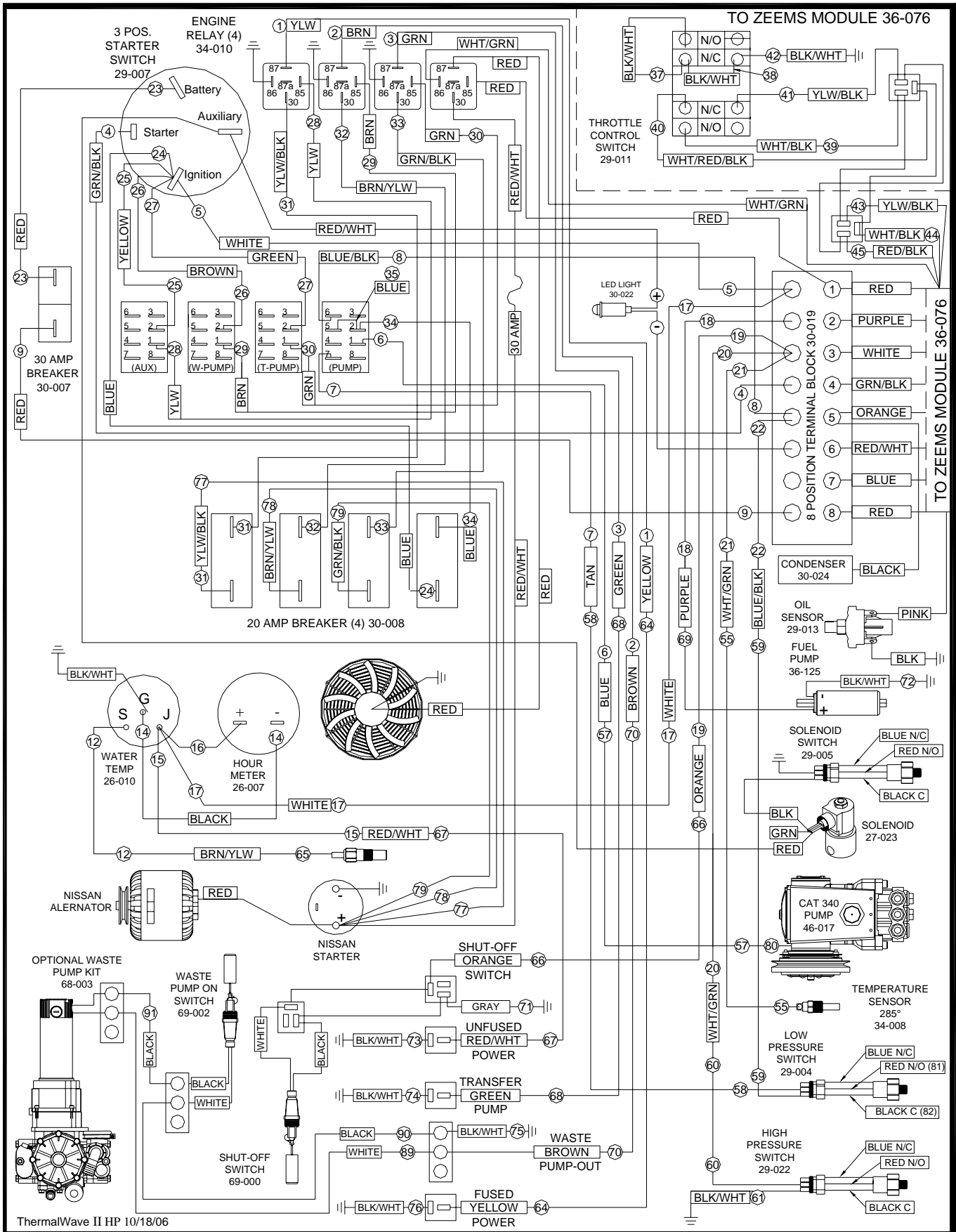

SECTION 5

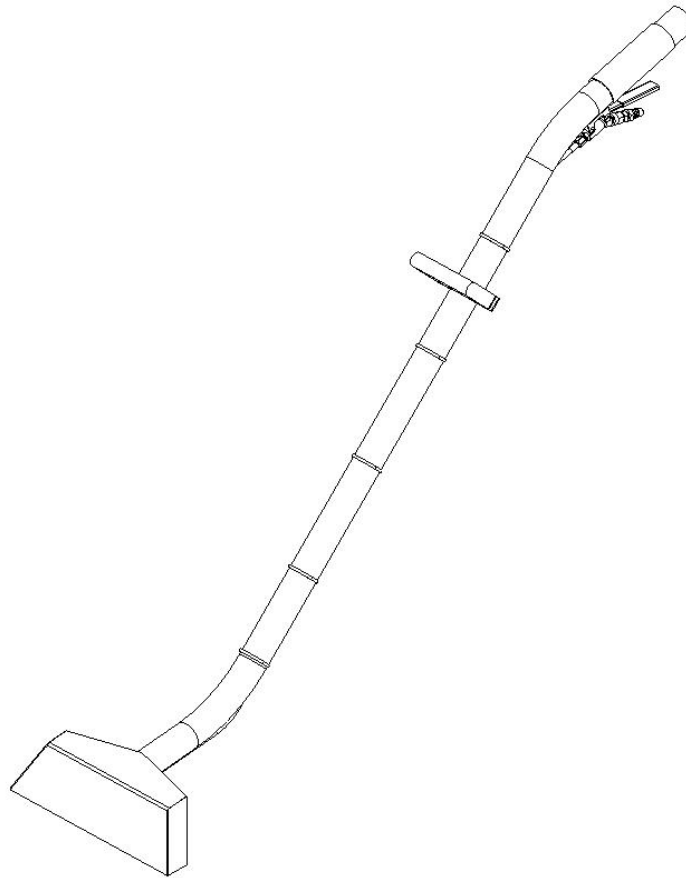

5-31

67-001 WAND, LOW PROFILE 2 IN.

Item No.	Part Number	Qty	Description
1	67-001	1	WAND, LOW PROFILE 2 IN
2	25-000	1	DSC, 1/4M X 1/4FP BR
3	27-013	1	VLV, WAND CMP
4	21-050	1	CONN, 1/4 P X 1/4 T BRASS
5	18-021	1	HOSE, 3/16 X 51 1/4FT X 1/4FT
6	24-000	4	TIP, SPRAY 95015X1/8P SST
	40-010	1	HANDLE, WAND REPLACENT

SECTION 5

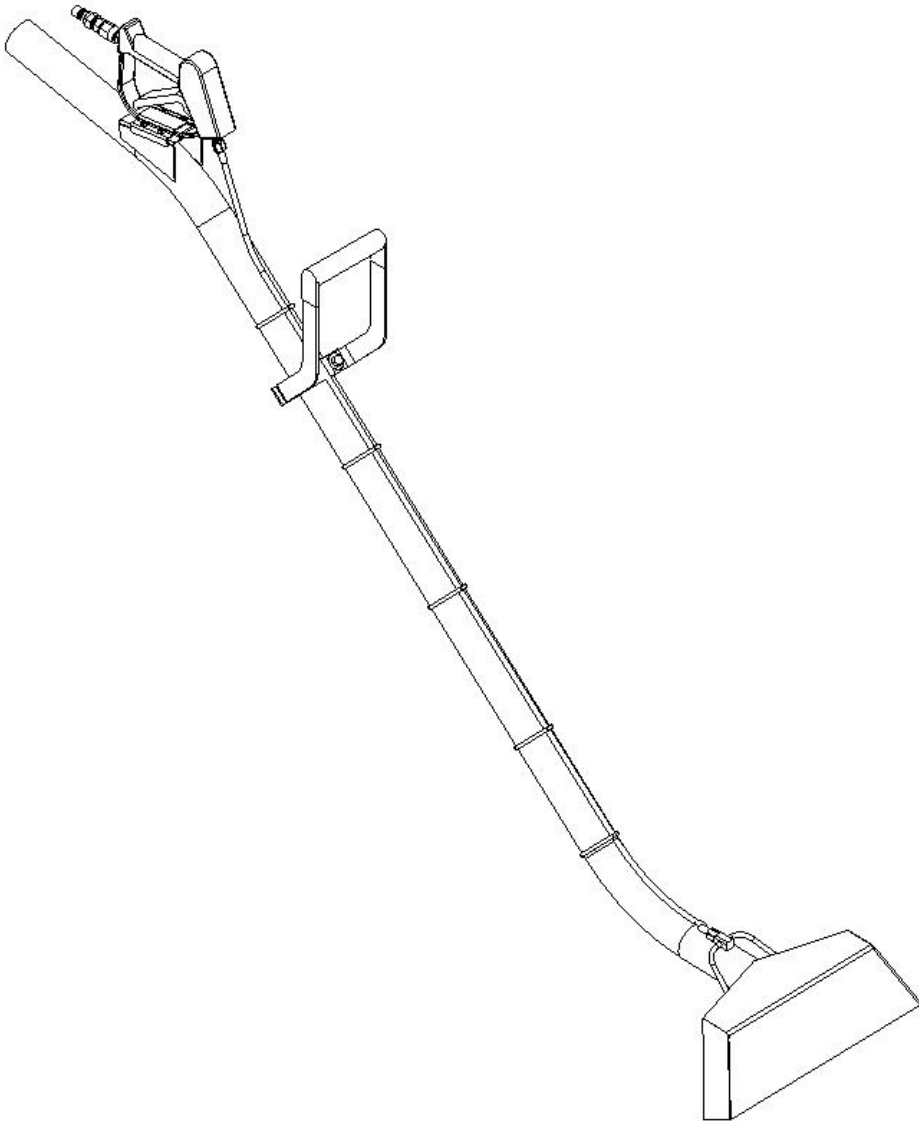

67-003 WAND, ERGONOMIC W-SPRAYER

Item No.	Part Number	Qty	Description
1	67-003	1	WAND,ERGONOMIC W /SPRAYER
2	25-000	1	DSC, 1/4M X 1/4FP BR
3	23-035	1	VLV,SPRAYER HYPRO 3381-0032
4	21-050	1	CONN, 1/4 P X 1/4 T BRASS
5	18-021	1	HOSE, 3/16 X 51 1/4FT X 1/4FT
6	24-000	4	TIP, SPRAY 95015X1/8P SST
7	40-009	1	HANDLE, ERGO WAND COATED

SECTION 5

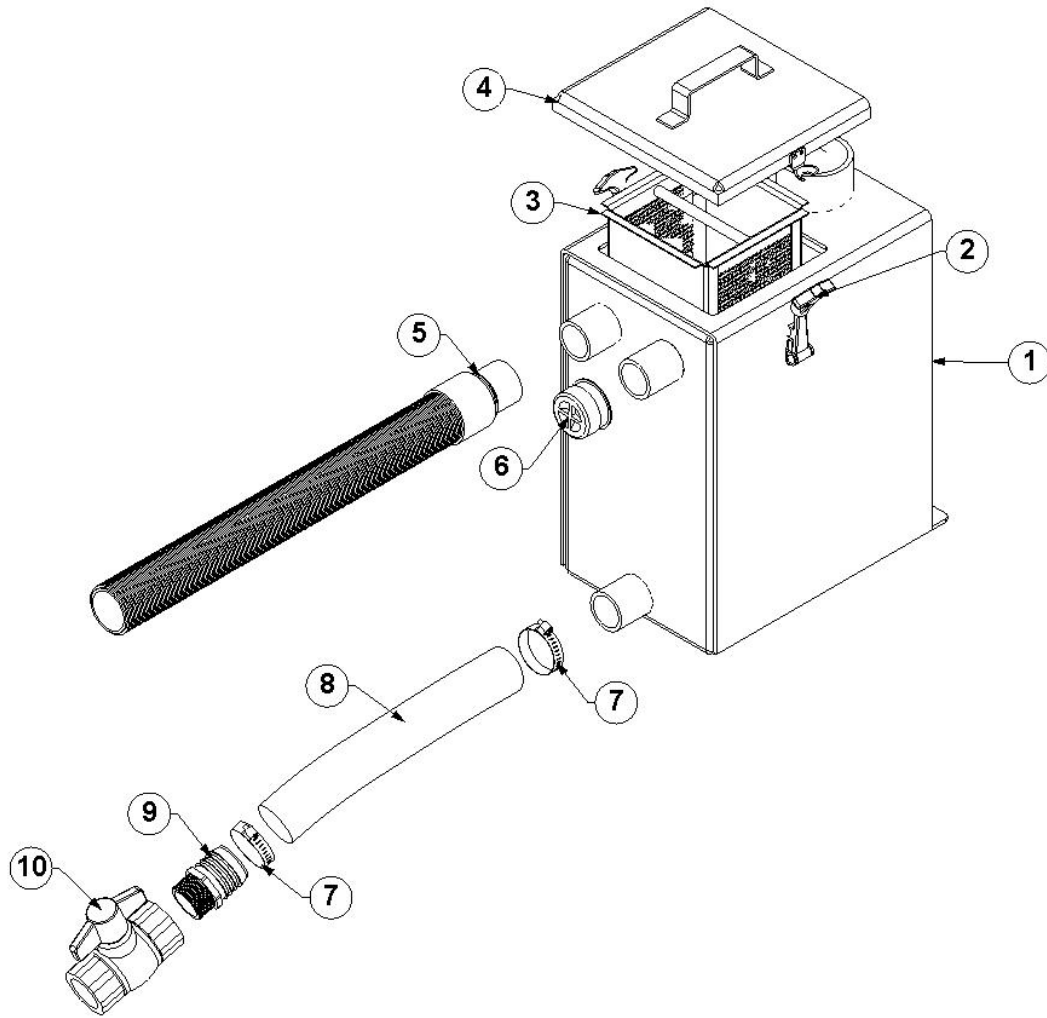

5-30

68-020 ASSY, PRE-FILTER BOX WASTE TANK V2

Item No.	Part Number	Qty	Description
1	61-012V2	1	ASSY, PRE-FILTER BOX V2
2	40-003	2	LATCH, PRE-FILTER BOX
3	61-039	1	ASSY, STRAINER BSKT PRE-FLTR BOX V2
4	61-020V2	1	ASSY, LID PRE-FILTER BOX V2
5	18-003	1	HOSE, VAC 2 IN. FLEX SUPER TM
6	19-009	1	CAP, WASTE TANK INLET
7	14-010	2	CLAMP, HOSE #32
8	17-421	1	HOSE, INT. VACUUM 2 IN X 6 FT
9	21-094	1	FTTG, 1-1/2 P X 2 H DRAIN
10	23-022	1	VLV, BALL 1-1/2 FP PVC DUMP

SECTION 5

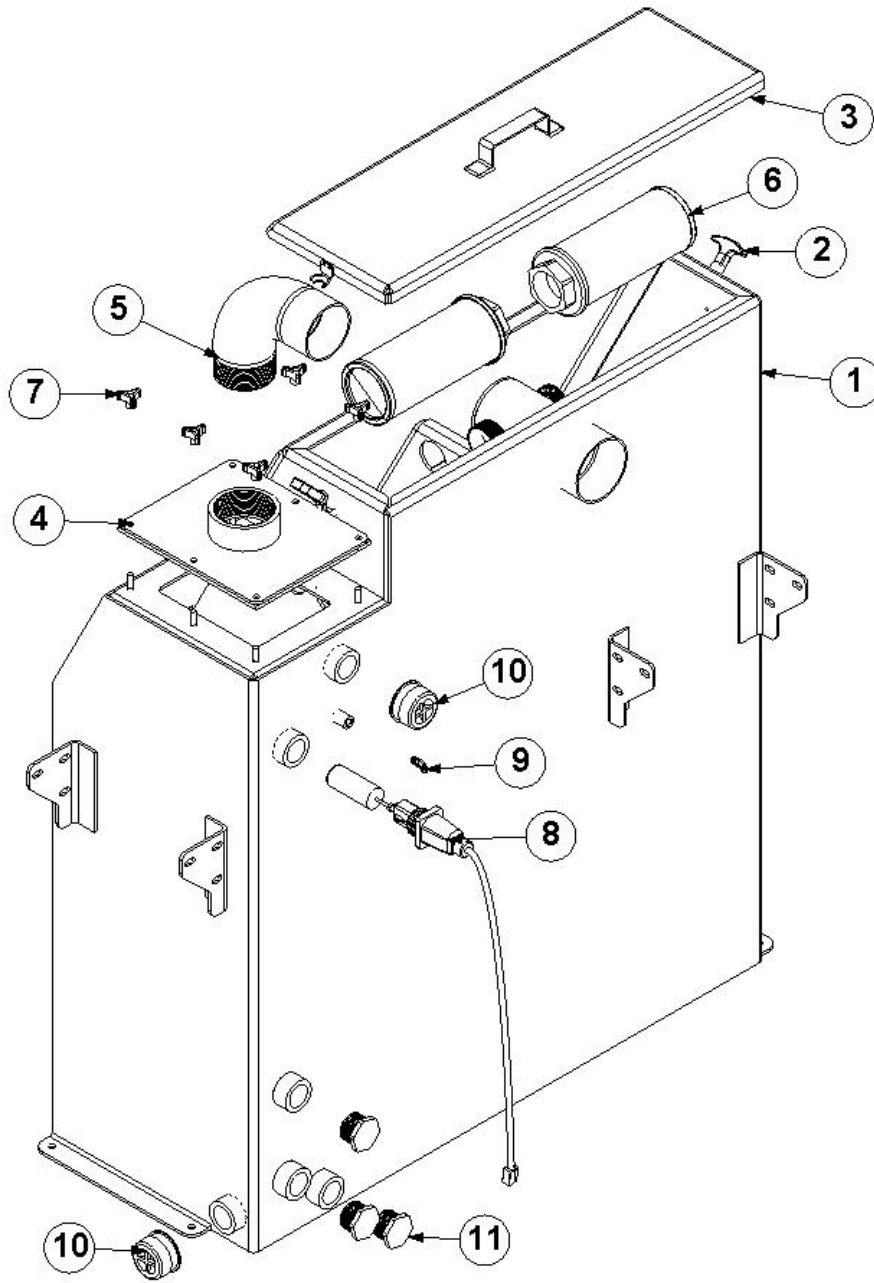

5-32

68-075 ASSY, BLUEWAVE 100 GAL WST TNK

Item No.	Part Number	Qty	Description
1	61-059	1	ASSY, WASTE TANK TWII
2	40-003	2	LATCH, PRE-FILTER BOX
3	61-037	1	ASSY, LID WST TNK REAR MT
4	61-024	1	PANEL, INLET ACCESS WASTE TANK
5	61-027	1	ELBOW, WASTE TANK INLET
6	20-004	2	STRAINER, WST TNK 2 IN. 100 MESH
7	10-031	6	SCREW, THUMB 5/16-18 X 3/4
8	69-000	1	WIRING , LEVEL SENSOR SHUTOFF
9	21-051	1	ELL, 1/4 P X 1/4 T 45 DEG BRASS
10	19-009	2	CAP, WASTE TANK INLET
11	21-097	3	PLUG, 1-1/4 IN PVC

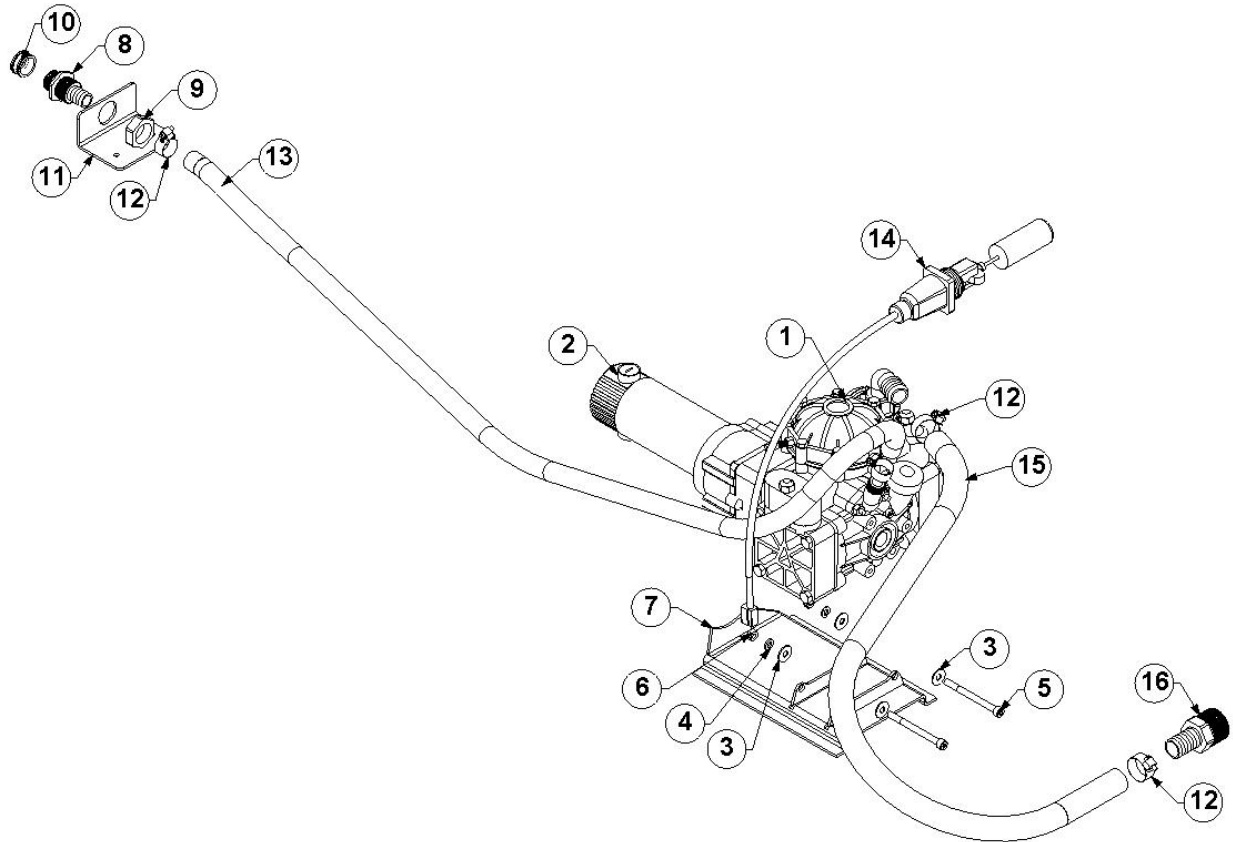
10. ACCESSORIES

5-34

68-003 KIT, WASTE PUMP EXTERNAL

Item No.	Part Number	Qty	Description
1	46-016	1	PUMP, DIAPHRAGM, PUMP OUT
2	45-008	1	MOTOR, GEAR BISON PUMPOUT
3	12-017	4	WASHER, FLAT 5/16 SAE
4	12-016	2	LKWSR, 5/16 ZINC
5	10-040	2	SCREW, MACH 5/16-18 X 3-1/2 SOCHD
6	11-005	2	NUT, 5/16-18 ZINC
7	61-003	1	MOUNT, EXTERNAL PUMPOUT
8	66-022	1	ADAPTOR, HOSE WASTE PUMP
9	66-023	1	NUT, ADPTR. HOSE WASTE PUMP
10	21-071	1	CAP, GARDEN HOSE 3/4 BRASS
11	58-006	1	BRKT, HOSE CONN WASTE PUMP
12	14-006	4	CLAMP, HOSE #20
13	16-004	72"	HOSE, WTR. 3/4 IN HRZ. 500FT BULK
14	69-000	1	WIRING, LEVEL SENSOR SHUTOFF
15	16-018	24"	HOSE, WTR. 1 IN HRZ. 100FT BULK
16	21-036	1	FTTG, BRB 1-1/4 P X 1 IN. BARB

1992 TO 2002 FORD FUEL LINE INSTALLATION

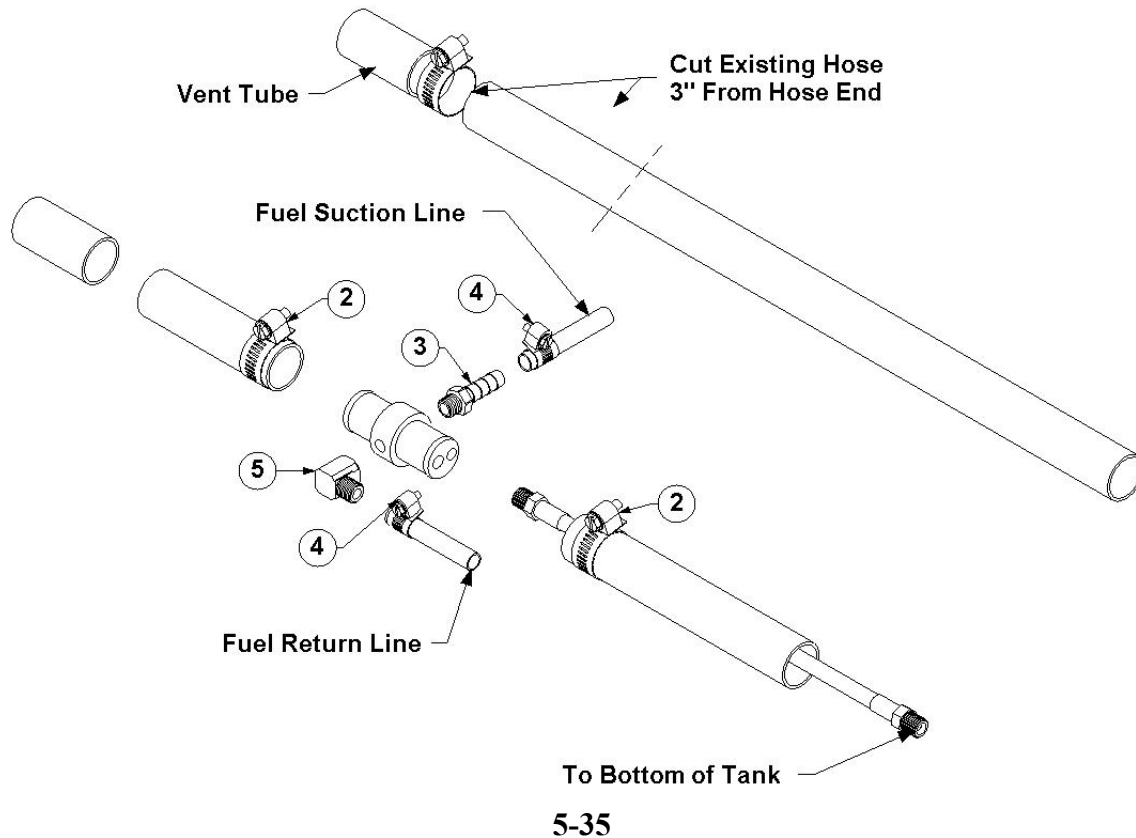

69-005FI KIT, FUEL HOOKUP FORD FI

Item No.	Part Number	Qty	Description
1	66-031	1	ADAPTOR, FUEL FILLER NECK FORD
2	14-000	2	CLAMP, HOSE #12
3	18-028	1	HOSE, 3/16 X 25 1/8P X 1/8P NO CVR
4	21-086	2	FTTG, BULKHEAD 1/4 IN. BRASS
5	21-006	4	FTTG, BRB 1/4PX5//16H BR
6	21-039	2	ELL, 1/4 IN LG STREET BRASS
7	14-011	6	CLAMP, HOSE FUEL #6
8	21-038	1	ELL, STREET 1/8 IN. BRASS
9	21-007	2	FTTG, BRB 1/8 P X 5/16 H BR

CHEVY AND GMC FULL SIZE VAN FUEL LINE INSTALLATION

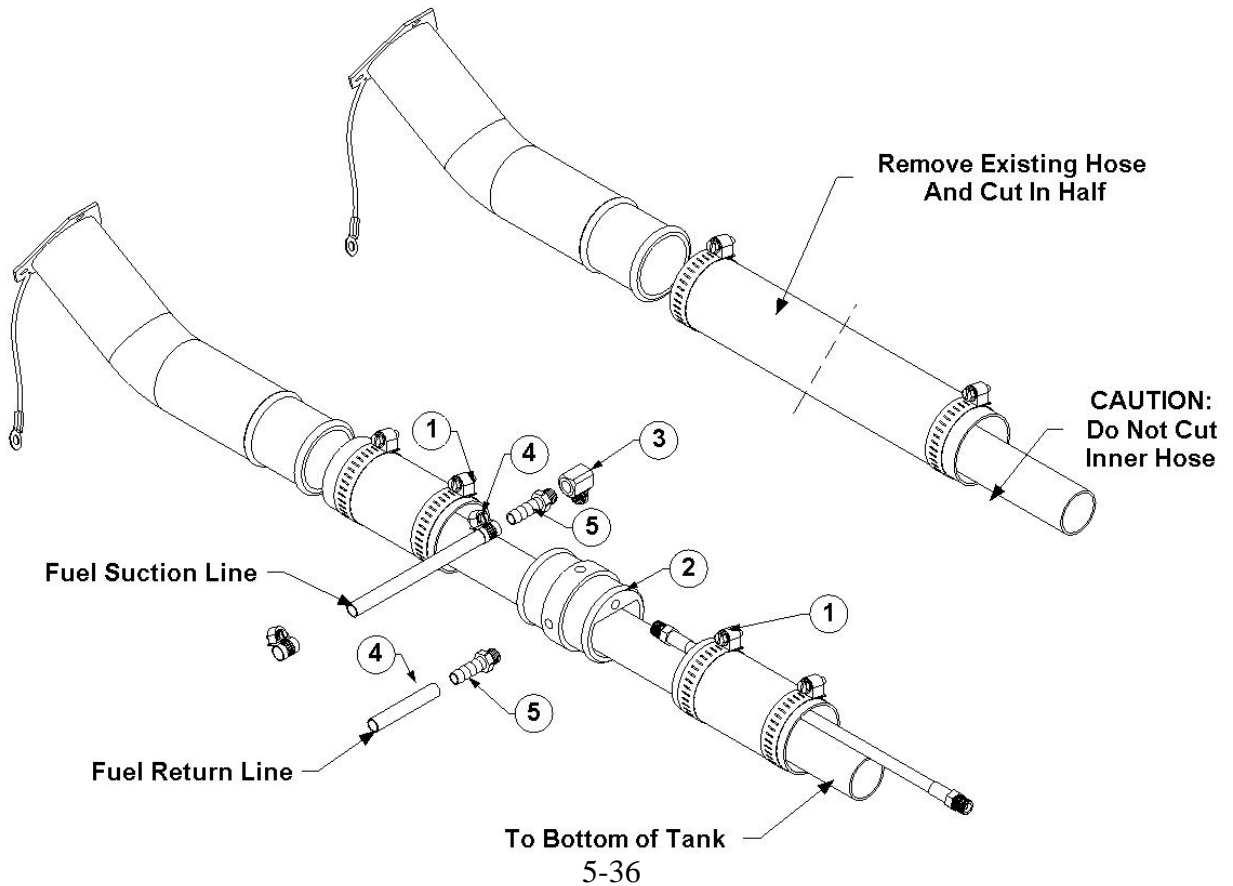

69-003FI KIT, FUEL HOOKUP 97 & 2002 FI

Item No.	Part Number	Qty	Description
1	14-010	2	CLAMP, HOSE #32
2	66-030	1	ADAPTOR, FUEL FILLER NECK CHEVY
3	21-116	1	ELL, 1/8FP 90 DEG BRONZE
4	14-011	6	CLAMP, HOSE FUEL #6
5	21-007	2	FTTG,BRB 1/8 PX 5/16 H BR
6	18-027	2	HOSE, 3/16 X 5 1/8P X 1/8P NO CVR
7	21-006	4	FTTG, BRB 1/4P X 5/16 H BR
8	21-039	2	ELL, 1/4 IN LG STREET BRASS
9	21-038	1	ELL, STREET 1/8 IN. BRASS
10	21-086	2	FTTG, BULKHEAD 1/4 IN. BRASS

SECTION 5

**2003 CHEVY AND GMC FULL SIZE VAN FUEL LINE
INSTALLATION**

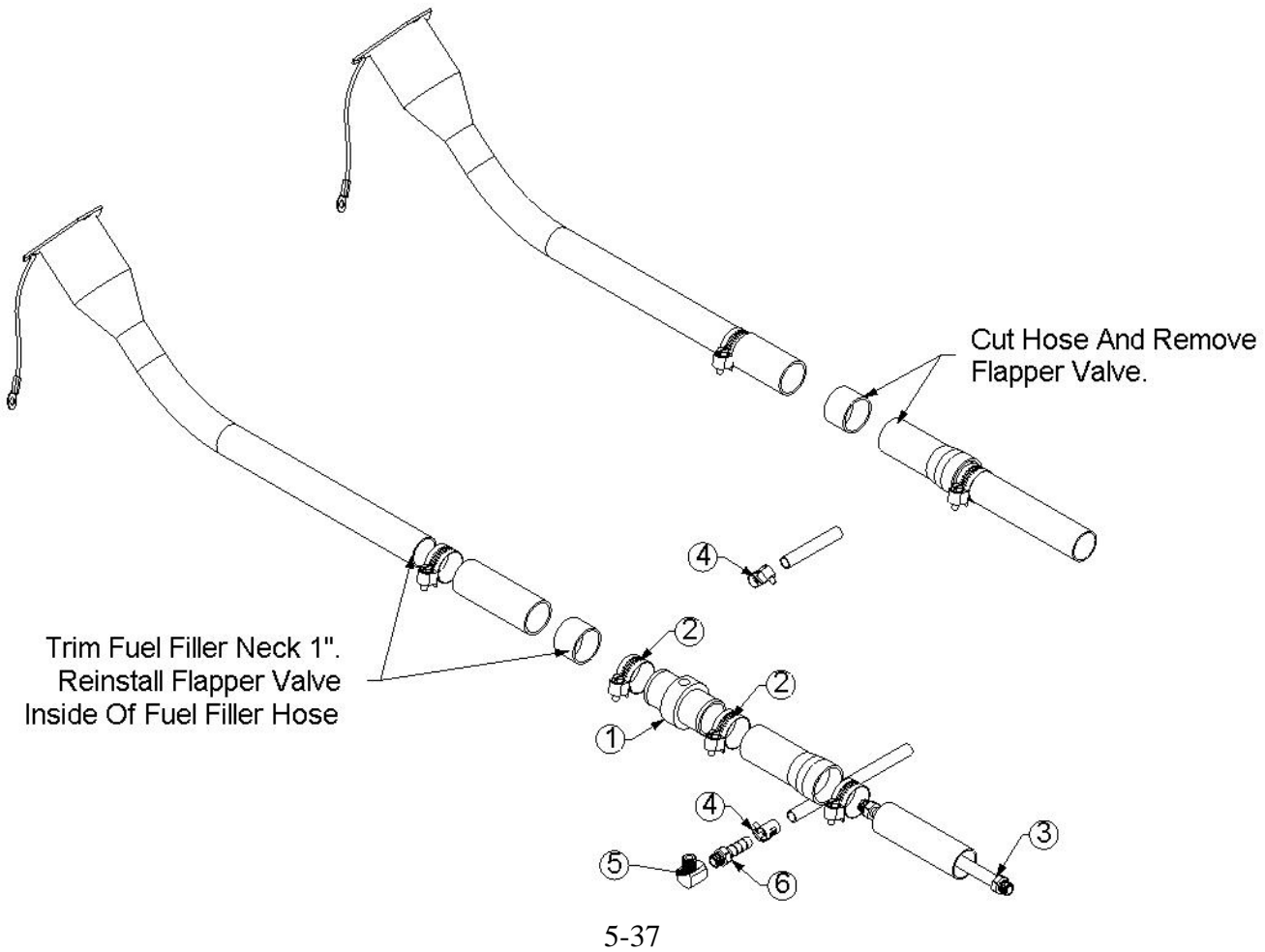

69-018FI KIT, FUEL HOOKUP 2003 CHEVY FI

Item No.	Part Number	Qty	Description
1	66-034	1	ADAPTOR, FUEL FLR CHVY 2003
2	14-006	2	CLAMP, HOSE #20
3	18-028	1	HOSE, 3/16 X 25 1/8P X 1/8P NO CVR
4	14-011	6	CLAMP, HOSE FUEL #6
5	21-038	1	ELL, STREET 1/8 IN. BRASS
6	21-007	2	FTTG,BRB 1/8 PX 5/16 H BR
7	21-039	2	ELL, 1/4 IN LG STREET BRASS
8	21-006	4	FTTG, BRB 1/4PX5//16H BR
9	21-086	2	FTTG, BULKHEAD 1/4 IN. BRASS

1997-2002 DODGE FULL SIZE VAN FUEL LINE INSTALLATION

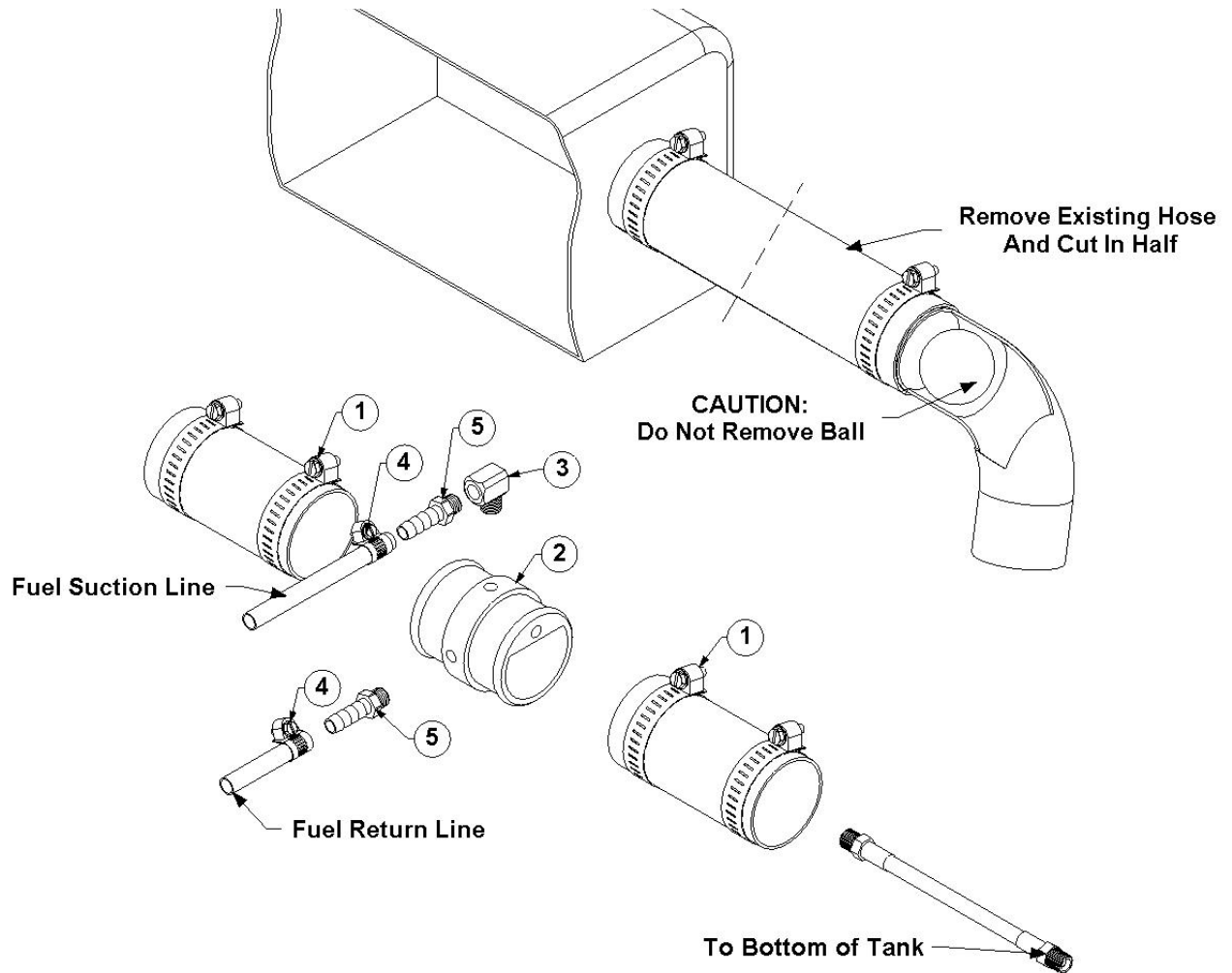

5-38

69-004FI KIT, FUEL HOOKUP CHEVY/DODGE FI

Item No.	Part Number	Qty	Description
1	14-010	2	#32 Hose Clamp (40/63mm)
2	66-030	1	ADAPTOR, FUEL FILLER NECK
3	21-038	1	ELL, STREET 1/8 IN. BRASS
4	14-011	6	CLAMP, HOSE FUEL #6
5	21-007	2	FTTG, BRB 1/8 PX 5/16 H BR
6	18-028	1	HOSE, 3/16 X 25 1/8P X 1/8P NO CVR
7	21-086	2	FTTG, BULKHEAD 1/4 IN. BRASS
8	21-006	4	1/4 M NPT x 5/16 Hose Barb
9	21-039	2	ELL, 1/4 IN LG STREET BRASS

SECTION 5

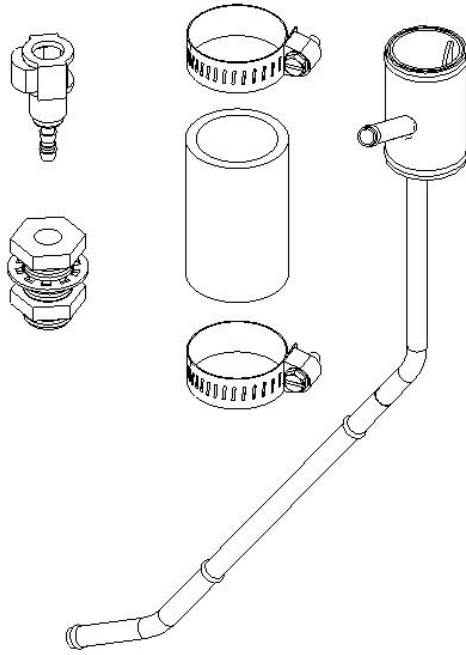

69-032 KIT, 2004 TF ADAPTOR CHEVY

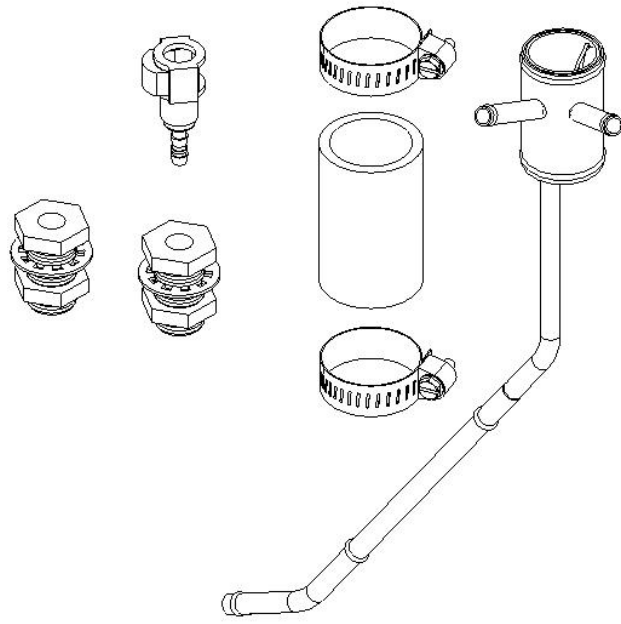

69-032FI KIT, 2004 TF ADAPTOR CHEVY

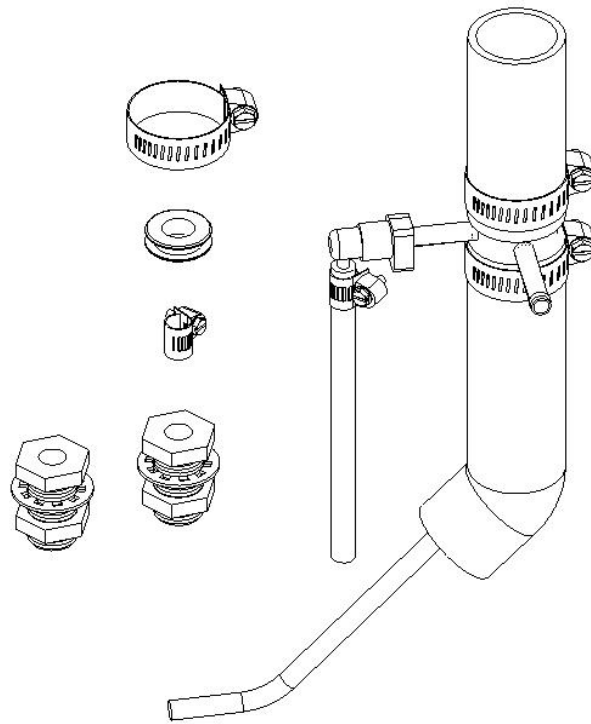

69-047 ADAPTOR, 2004 FUEL FORD

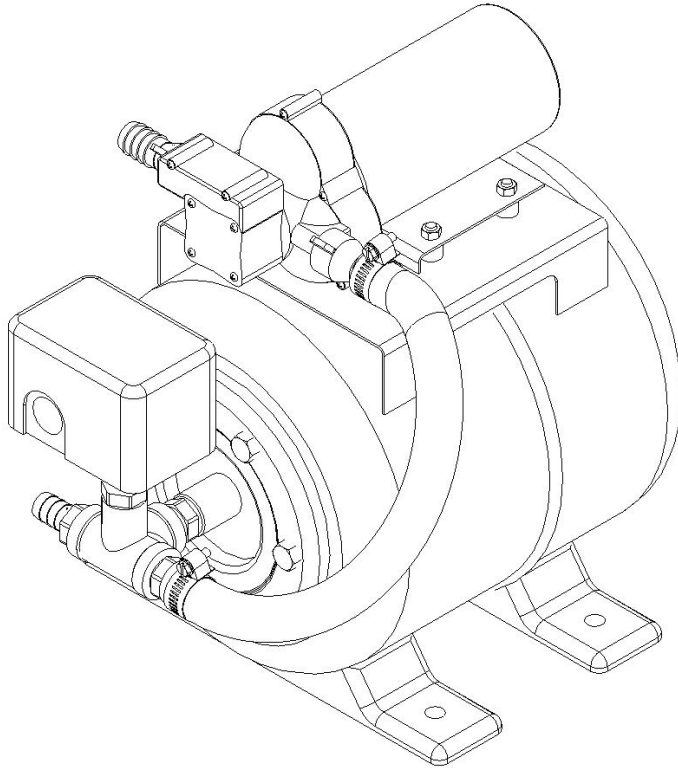

5-39

68-002 KIT, DEMAND PUMP W/PLUMBING SS

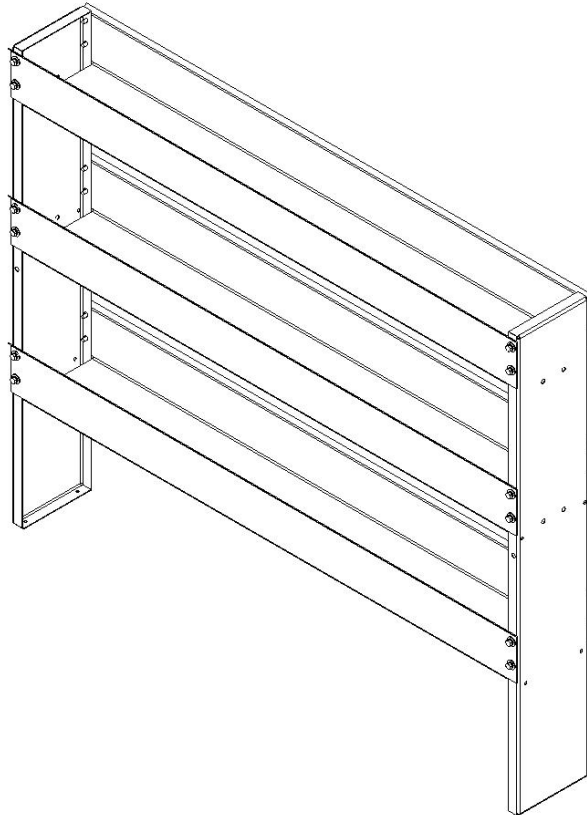

5-40

68-013 ASSY, VAN STORAGE UNIT SS

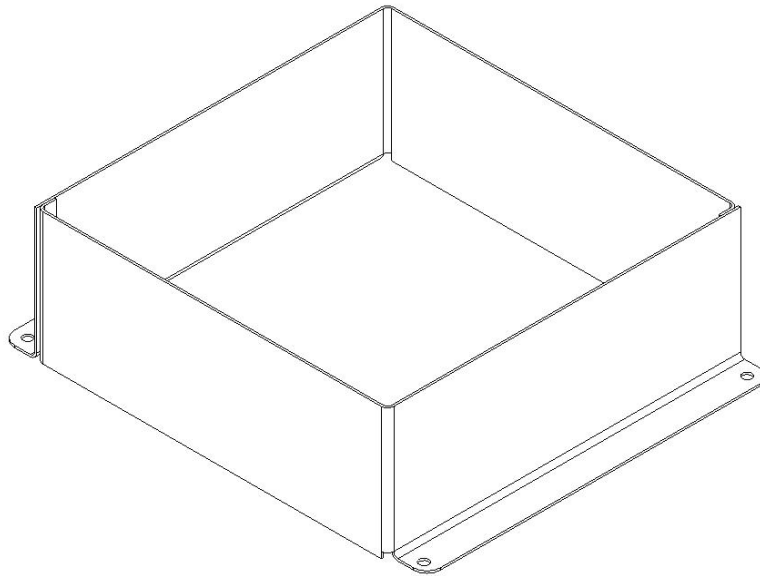

5-41

68-014 ASSY, SINGLE 5 GAL JUG HOLDER

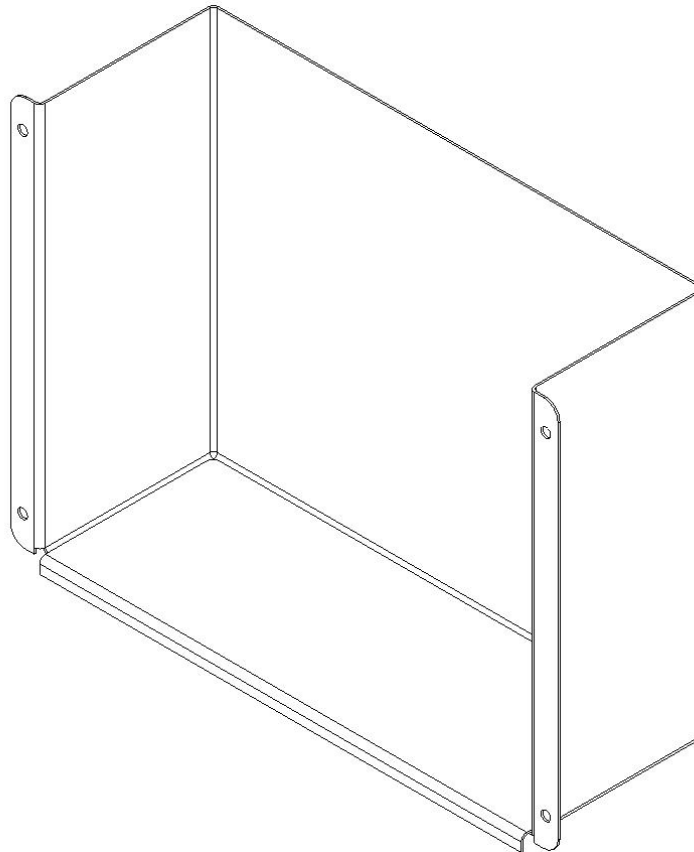

5-42

68-015 ASSY, FURN BLOCK HOLDER SS

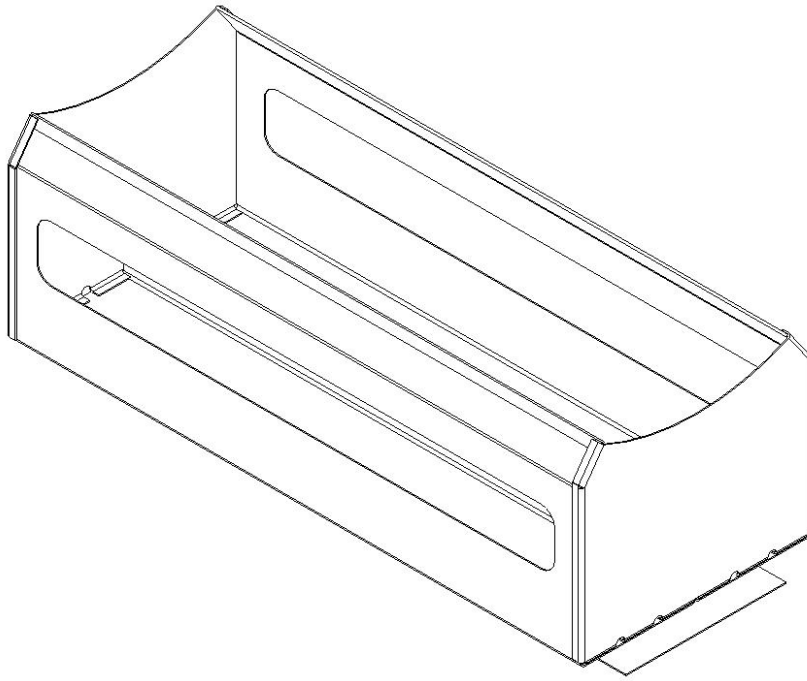

5-43

68-016 RACK, DOUBLE CHEMICAL

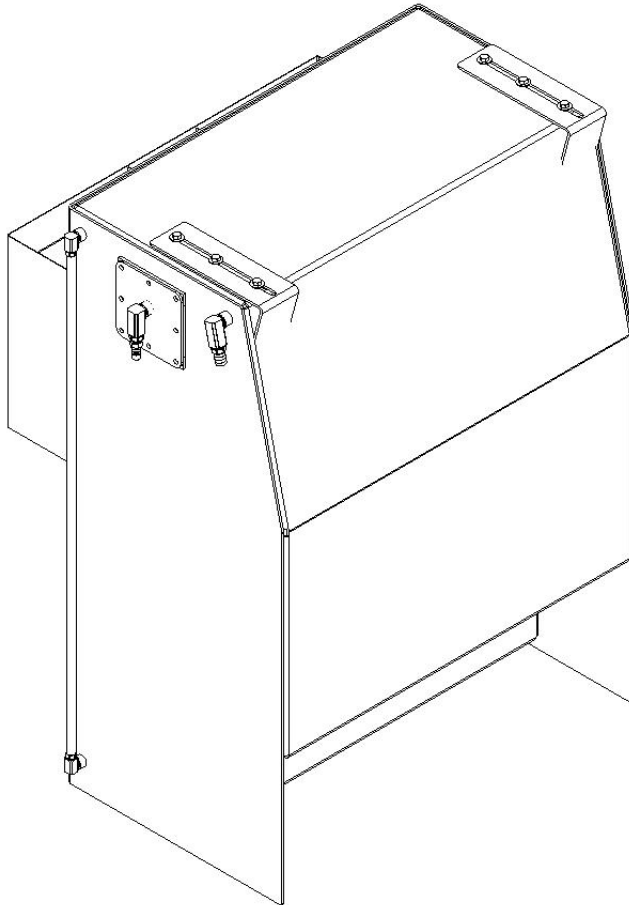

5-44

68-017 ASSY, FIN 120 GAL WTR TNK

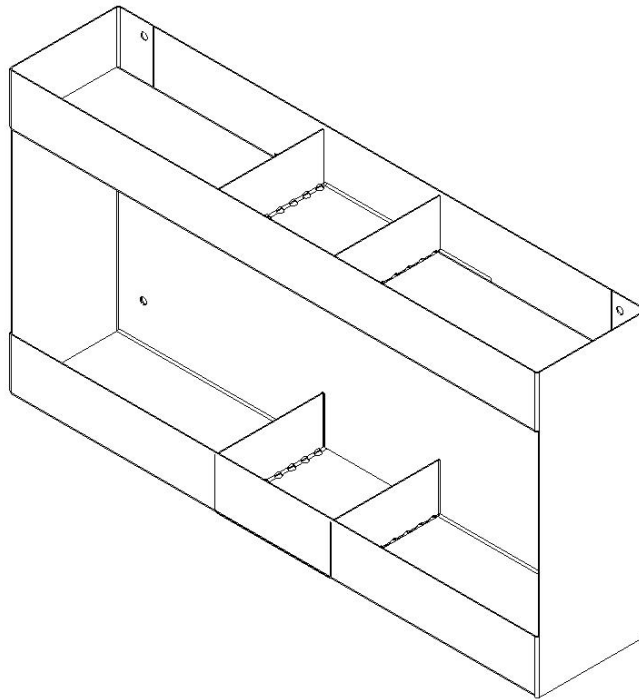

5-45
68-018 ASSY, 10 GAL CHEM RACK S.S.

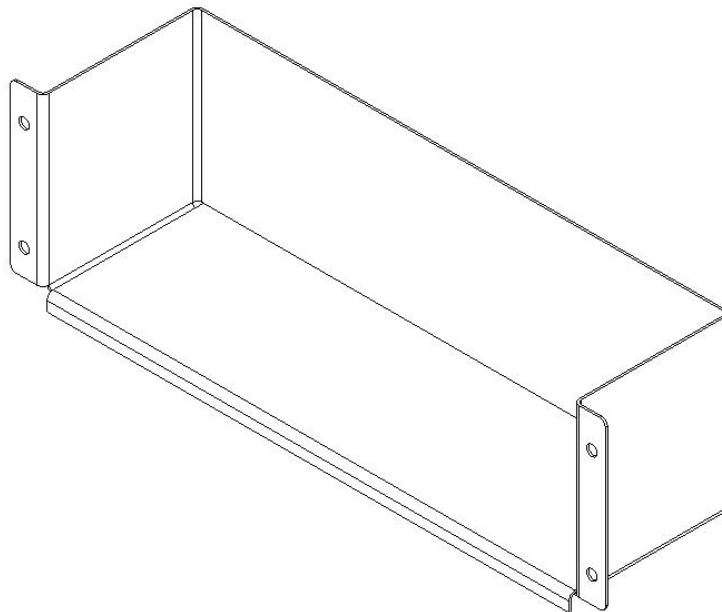

5-46
68-019 SPRAY BOTTLE HOLDER SS

SECTION 5

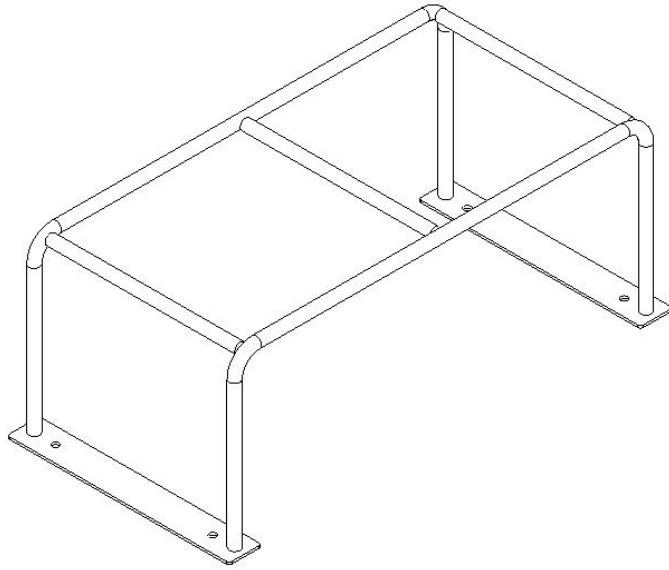

5-47

68-022 ASSY, DBL PMP UP SPRAY RK, SS

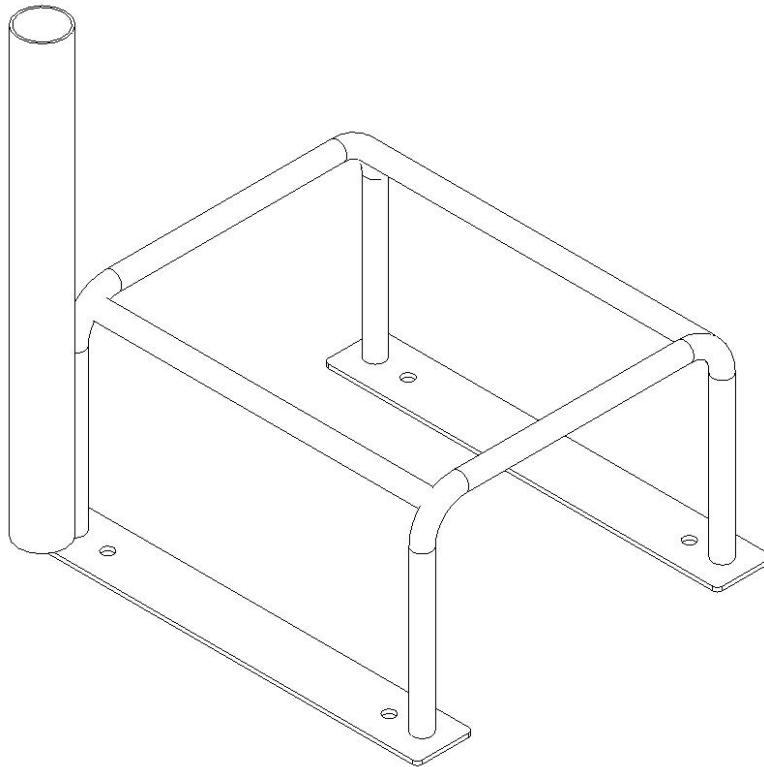

5-48

68-024 ASSY, SNG PMP UP SPRAY RK, SS

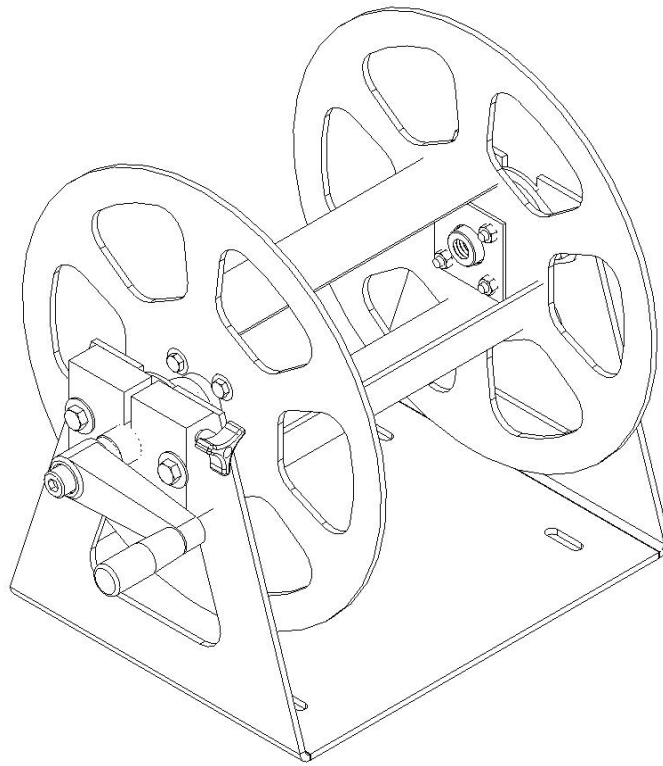

5-49

68-023 ASSY, REEL HP SOLUTION

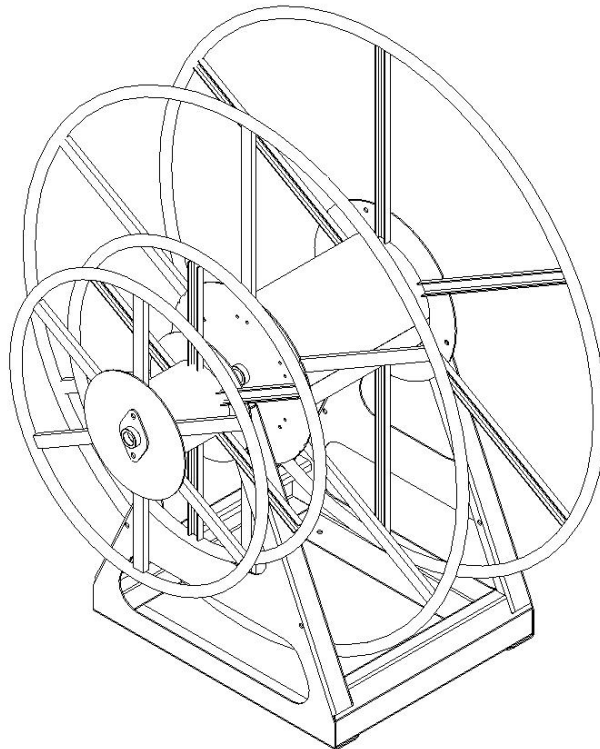

5-50

68-025 ASSY, HOSE REEL HIGH PROFILE

SECTION 5

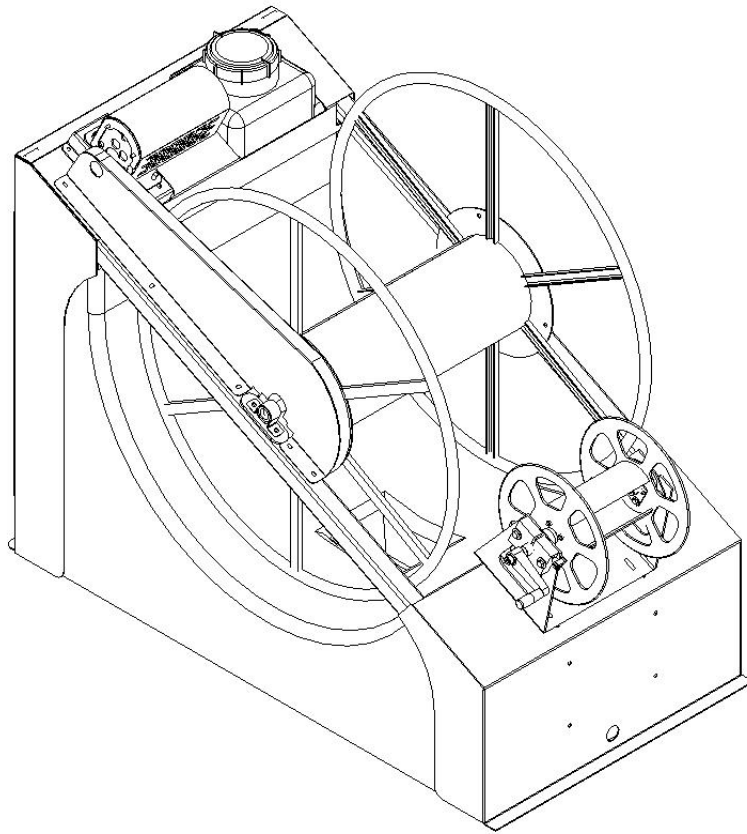

68-032 ASSY, H-REEL MOTORIZED W-H2O TNK

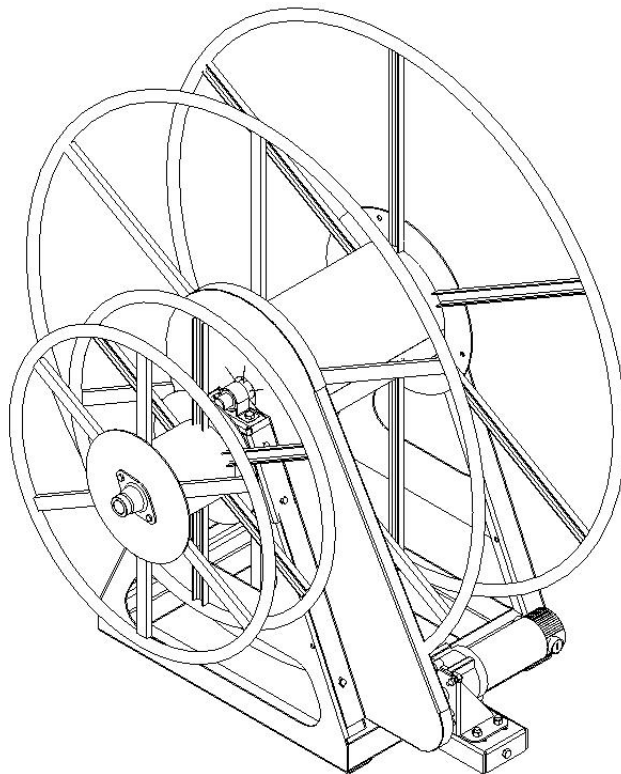

68-033 ASSY, HOSE REEL H. PROFILE W-MTR

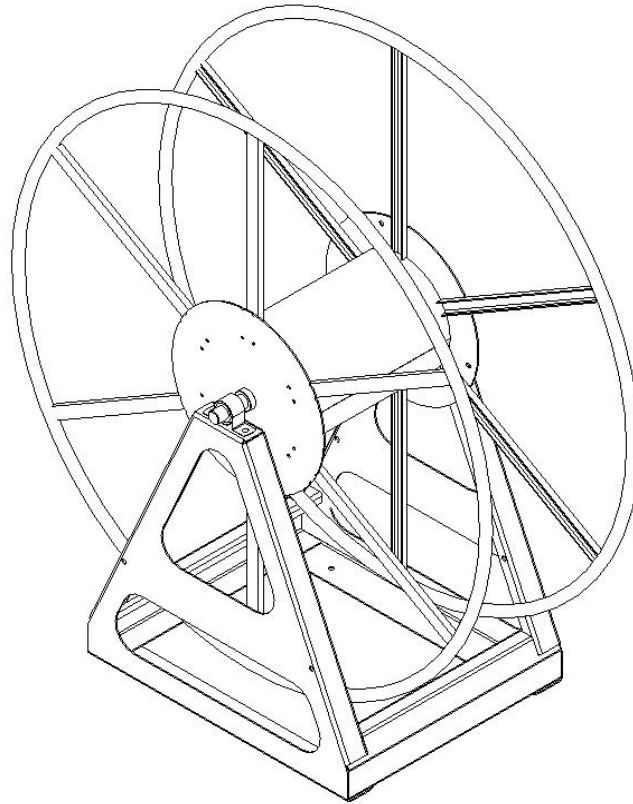

68-037 ASSY, HOSE REEL VAC ONLY

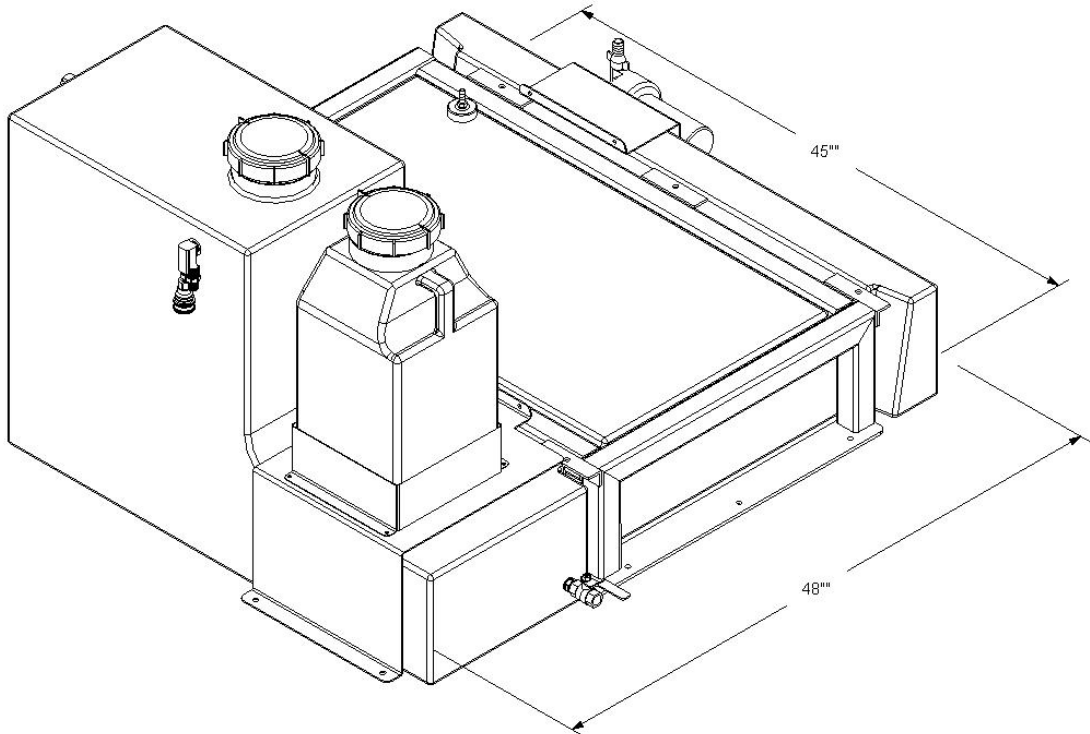

68-059 KIT, SUB MOUNT WATER TANK

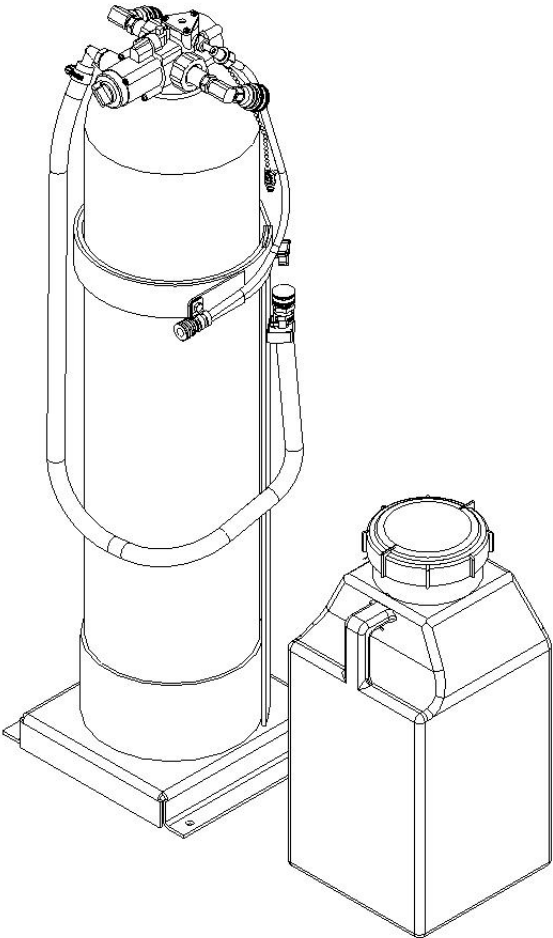

68-045 ASSY, WATER SOFTENER